

BALL VALVES - SPECIAL SERVICE

SHORT VERSION

[Click here](#) for complete version of this catalogue



**AUSTRALIAN
PIPELINE VALVE®**

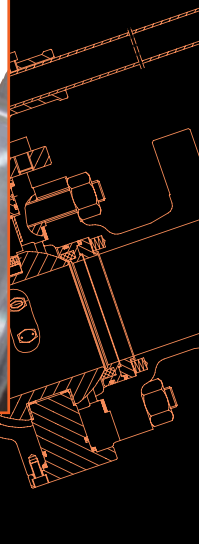
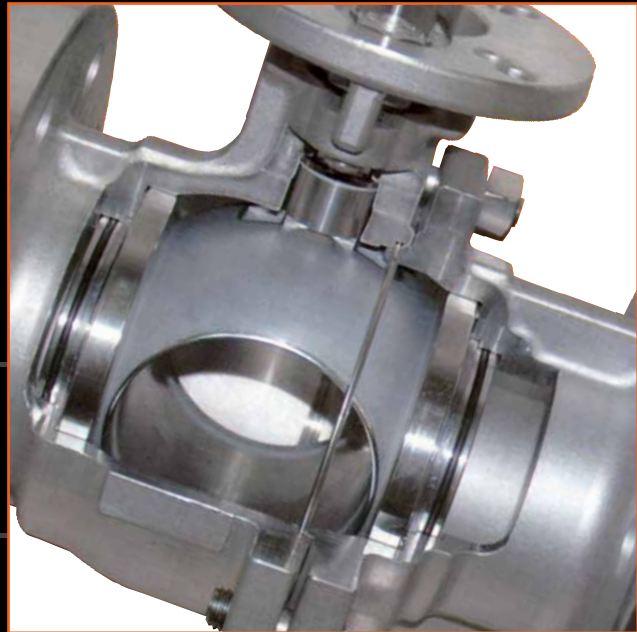
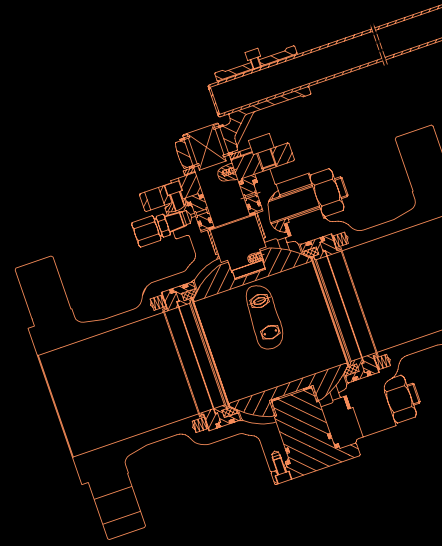
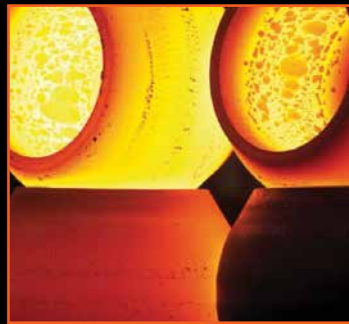

API 622 & ISO 15848-1
Fugitive Emission Certified



API 607 6th Ed. & ISO 10497
Firesafe Certified



QUALITY VALVE MANUFACTURER

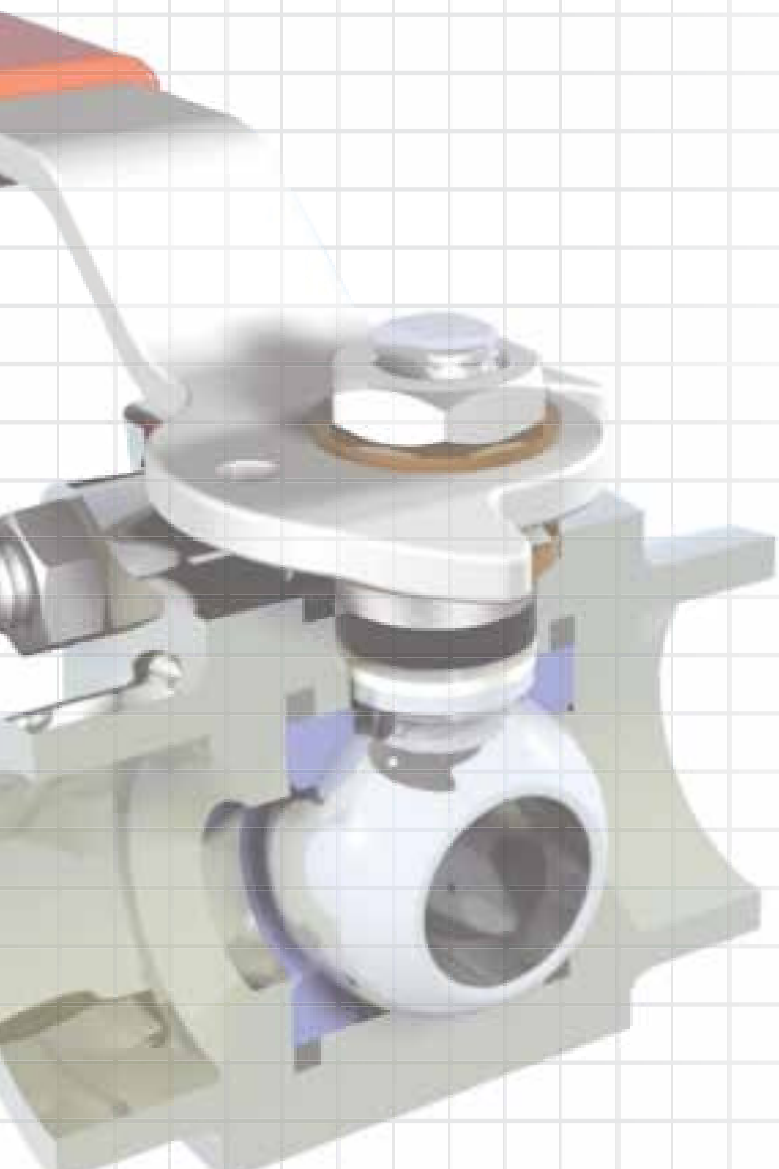

QUALITY COMMITMENT

Quality is Our First Priority.

Consistent product quality and a proven track record makes Australian Pipeline Valve a dependable choice where total reliability is the number one concern.

Since its founding, APV's philosophy has been focused on quality. Our valves are manufactured in full compliance to worldwide standards (such as ASME/ANSI, API, EN, ISO, BS, AS).



**AUSTRALIAN
PIPELINE VALVE®**

70-78 Stanbel Road Salisbury Plain South Australia 5109

Telephone +61 (0)8 8285 0033

email: admin@australianpipelinevalve.com.au

CONTENTS

Firesafe & Fugitive Emission Certification	4~7 *
Standards & Specifications	8 *
Valve Materials & Service Applications	9~10 *
Metal Seated Trunnion & Floating Overview	11~12 *
Metal Seated Trunnion Ball Valve FS9000-MS	13~15*
Metal Seated Floating Ball Valve SLFSBV01-MS	16~17*
Metal Seated Floating Ball Valves BV100-MS	18 *
Metal Seated Full Port Ball Valves KI-L830 Series	19~20*
Seating Systems Trunnion Ball Valve	21~23 *
Ceramic Ball & Disc Slide Valves	24~26 *
Rising Stem, Top Entry Ball Valve	27~35 *
Pig Type Ball Valve	36~39 *
Double Block & Bleed Ball Valve	40~45 *
Floating Ball Valve DB&B BVF100-F26	46~47 *
Single Ball Floating Design DB&B SLFSBV01-DBB	48 *
Welded Body Trunnion Mounted Ball Valves BVF100/QF/QS/RG/CV	49~51 *
Top Entry Forged & Cast Steel Ball Valves FSTE/CSTE Series	62~74 *
V-Port Segment Ball Control Valves	75~77 *
Technical Liability Limitations	78

* This version excludes some of these pages, refer to full version at website.



API 622 2011 2nd Edition
Endurance Test Certified



© Copyright Australian Pipeline Valve 1990 - 2023 Edition

Catalogues, photos, brochures and technical publications are the exclusive property of Australian Pipeline Valve. Any unauthorised reproduction in total or in part, shall result in prosecution. Products and data sheets in this publication are subject to change at anytime without notice. Australian Pipeline Valve reserves the right to carry out amendments to products and materials.

FIRESAFE & FUGITIVE EMISSIONS CERTIFICATES



DNV WITNESSED

Australian Pipeline Valve is one of the few companies in the world to hold firesafe certification to the latest 6th edition of AP I607 and ISO 10497. In addition, APV ball valves are fugitive emission certified to ISO 15848.



Endurance Test Certified



API 607 6th Ed. & ISO 10497
Firesafe Certified



API 622 & ISO 15848-1
Fugitive Emission Certified



METAL SEATED BALL VALVE TRUNNION & FLOATING OVERVIEW

For certain applications such as abrasive media or high temperature, it is unthinkable to use soft seated ball valves and the best solution would be to have a top quality metal seated valve at a reasonable price.

APV is glad to introduce it's range of METAL SEATED BALL VALVES, a high performance, high quality, standard production ball valve with competitive price and relatively short delivery term.

APV meets the market demand for a valve that will perform critical service but which can be tailored to suit different needs at a cost effective price.

The production of APV METAL SEATED ball valves has been divided in two different categories: LOW PRESSURE / HIGH TEMPERATURE and CORROSIVE / ABRASIVE SERVICE.

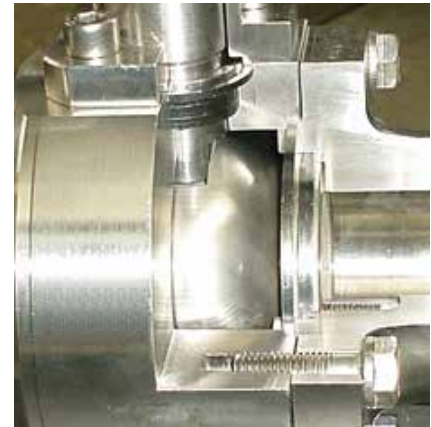

FS9000-MS

- Precision machined external stem bearings eliminate radial movement which causes packing wear.
- Extensive stuffing box with dual anti-extrusion rings keeps packing in place and eliminates leak paths.
- Tested to MSS-SP-61, API 598, ISO 5208 or Class V or VI shutoff.
- The ball and seats are mate-lapped for 100% sealing area contact which ensures absolute shutoff.
- Fire safe to API 607 5th & 6th Edition.
- The ball protects the seats from flow when the valve is open or closed which reduces wear on sealing surfaces.
- The seat spring combined with line pressure provides a constant mechanical force while allowing for thermal expansion.
- Each valve is individually tested prior to leaving the factory.
- All pressure containing components meet or exceed the ASME B16.34 and ASME Section VIII standards, and API 6D.

FULL BORE CV INFORMATION

Valve Size	150#	300#	600#	900#	1500#	2500#
1/2	26	26	26	26	26	20
3/4	62	62	62	52	52	33
1	114	114	114	85	85	62
1-1/2	271	271	271	223	223	145
2	498	498	498	432	432	271
2-1/2	799	799	799	640	640	432
3	1176	1176	1176	1071	978	640
4	2159	2159	2159	2014	1749	1071
6	5076	5076	5076	4641	4019	2603
8	9300	9300	8985	8120	7023	4641
10	14866	14866	14096	12966	11289	7561
12	21800	21800	20857	18579	16045	10881

This brochure is general in nature and can vary at any time without notice

DIMENSIONS & MATERIALS

Please refer to APV Soft Seat Split Body dimension tables & materials. Ball, seat and stem can be hardened chrome, tungsten carbide, stellite, nitrided to 900 Hv 0.3mm etc.



FS9000-MS SERIES - DESIGN FEATURES



Stem
Hard Surfaced
Multi-Packing Design
Anti-Blow-Out
Anti-Static



Seat Design
Designed to 'scrape off' and resist slurries, muds or other viscous fluids & solid mediums. Special Hardened Surface Treatment: Stainless Steel + HCr/TC/Stellite etc.

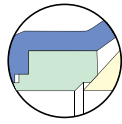

Flexible Graphite Stem Packing
For Severe Services &
High Temperature

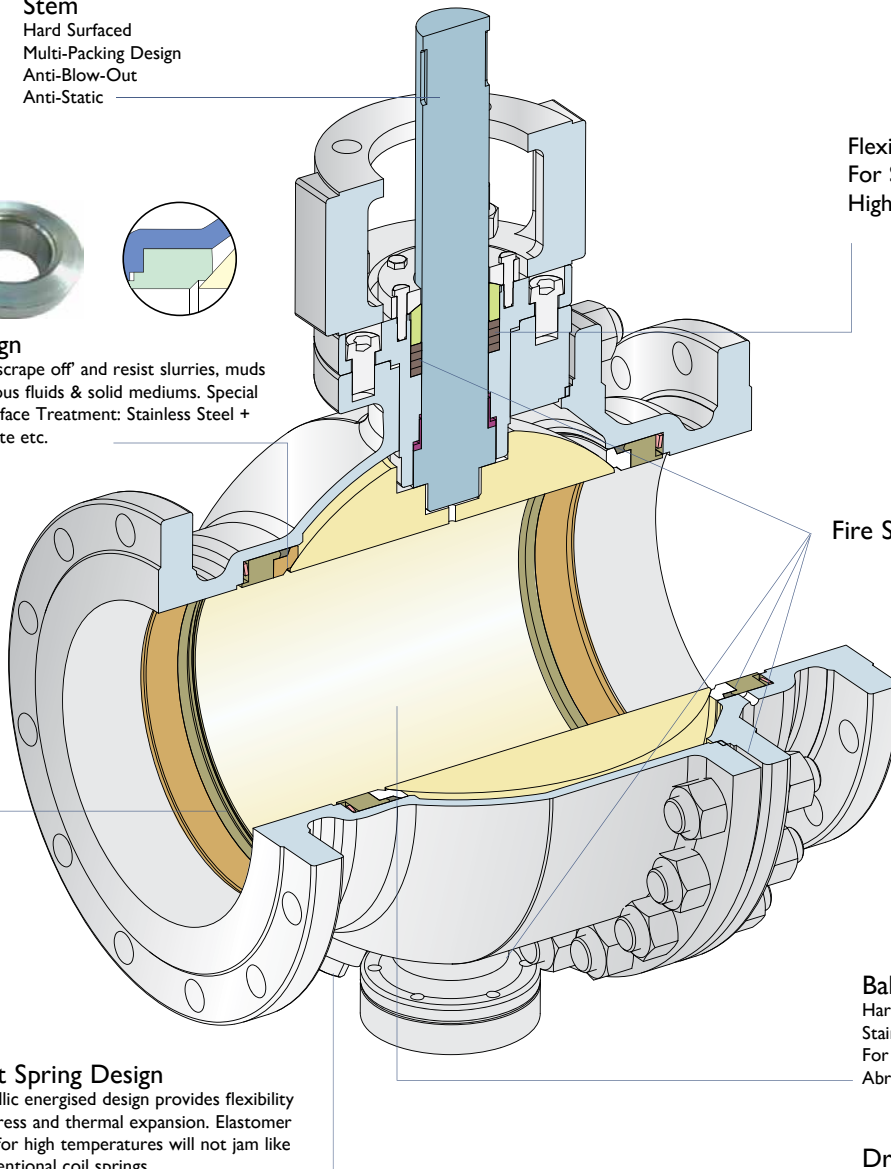

Fire Safe Design

Seat Spring Design
Metallic energised design provides flexibility to stress and thermal expansion. Elastomer free for high temperatures will not jam like conventional coil springs.



Ball
Hardened Surface Treatment
Stainless Steel +HCr/TC/Stellite...etc.
For High Temperature,
Abrasive Services



Drain
For drain or DB&B

Double Contact Metal Seat Design



Profiled Metal Seat Design

Slight roundness of the seat ensures continuity of contact.

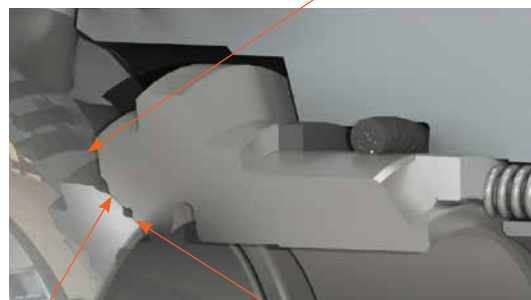

Rigid metal permanent contact absorbs seat thrust due to differential pressure.

Flexible metal permanent contact provides seal irrespective of non-uniform deformation of the sphere.

Indicative design only. Numerous design configurations available depending on size class etc.

SLFSBV01-MS SERIES METAL SEATED BALL VALVE FLOATING - FLANGED STYLE

 FIRESAFE CERTIFIED API 607 6TH
EDITION AND API 6FA 3RD EDITION

Body materials	Cast Steel (WCB), Stainless steel (CF8M) etc
Pressure rating	ANSI 150, 300 & 600
Temperature	10°C ~ 500°C
Size	15mm ~ 300mm (1/2" ~ 8")
Applications	High temperature, Abrasive & corrosive Services
Construction	Stainless steel seat & ball, graphite gasket for body sealing, anti blow-out stem. Both seats are 304SS or 316SS stellite, nitrided or hard chrome. The ball is 304SS or 316SS stellite or hard chrome/nitrided. The stem is 304SS or 316SS or 17-4PH hardened/nitrided or stellite.



FEATURES

- Same face to face dimensions as API 6D standard teflon seated ball valves for easy changeover and replacement
- Quick 90° operation
- Full through flow - no obstruction to fluid, minimum pressure drop
- Long service life

1. Durability

The metal contact mechanism between ball and seat is ensured by spring energised seat and provides long life.

2. Half opening control

The metal mechanism enables the possibility of half opening the valve to control flow. Consult us, as options like V-Port may need to be considered. Also extreme wear through cavitation can occur when valve is in half open position.

3. Low torque operation

Small friction coefficient between ball and seat, and spring energised seats make manual operation easy.

4. Leakage

The seat is spring energised against the ball to maximise the effectiveness of the seat sealing process. Design is class V or VI and ISO 5208 rate A & AA shut off, uni-directional (also available bi-directional)



API 622 & ISO 15848-1
Fugitive Emission Certified



API 607 6th Ed. & ISO 10497
Firesafe Certified



AS 4617, AS 4629

BV100-MS SERIES (MODEL K1-L830) METAL SEATED BALL VALVE 8~50NB

Size Range 1/4" - 2" (DN8 - DN50)
Pressure Rating 2000 PSI (800 Class)
End Connection Threaded, Socket Weld and Buttweld
Service Application Slurries, Pulp Stock, Solid-Containing Fluids
Firesafe API 607

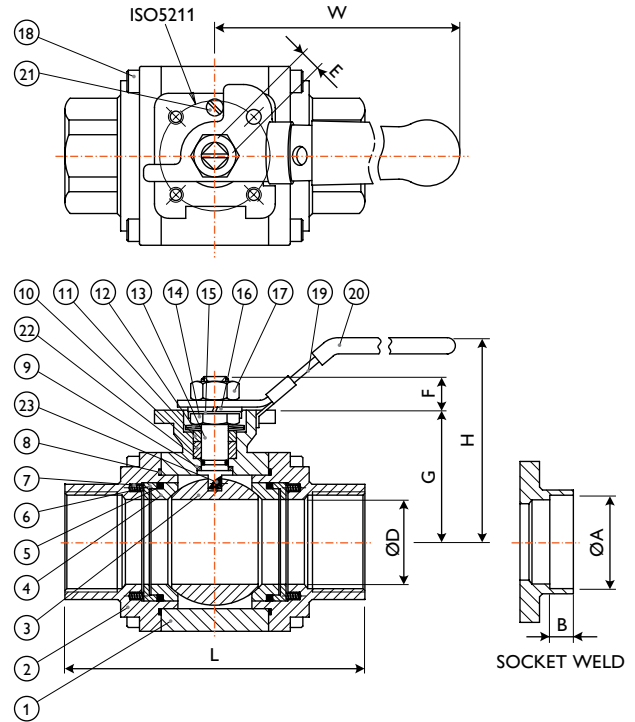

MATERIAL LIST

Item	Description	Stainless Steel	Carbon Steel	Q'ty
1	Body	ASTM A351 CF8M	ASTM A216 WCB	1
2	Body Cap	ASTM A351 CF8M	ASTM A216 WCB	2
3	Ball	ASTM A351 CF8M/316 (Hardened / Coatings)	ASTM A351 CF8M/316 (Hardened / Coatings)	1
4	Seat	ASTM A276 316 (Hardened / Coatings)	ASTM A276 316 (Hardened / Coatings)	2
5	Seat Gasket	Graphite	Graphite	2
6	Seat Packing	AISI 304	AISI 304	2
7	Seat Spring	JIS G3565 SWOCV-VI ASTM A276 304 ASTM B637 Inconel X-750	JIS G3565 SWOCV-VI ASTM A276 304 / ASTM B637 Inconel X-750	8-16
8	Body Gasket	PTFE	PTFE	2
		Graphite	Graphite	2
9	Thrust Washer	PTFE	PTFE	1
		Graphite	Graphite	1
10	Stem Packing	Graphite	Graphite	1
11	Gland	AISI 304	AISI 304	1
12	Belleville Washer	DIN 17221 50CrV4	DIN 17221 50CrV4	2
13	Stem	ASTM A276 316 / ASTM A564 17-4PH	ASTM A276 316 / ASTM A564 17-4PH	1
14	Gland Nut	AISI 304	AISI 304	1
15	Lock Clip	AISI 304	AISI 304	1
16	Spring Washer	AISI 304	AISI 304	1
17	Handle Nut	AISI 304	AISI 304	1
18	Body Bolt	ASTM A193 B8	ASTM A193 B7	8-12
19	Handle	AISI 304	Zinc Plated Steel	1
20	Sleeve	Vinyl Plastisol	Vinyl Plastisol	1
21	Stop Pin	AISI 304	Carbon Steel	1
22	Stem O-Ring	Viton	Viton	1
23	Anti-Static Device	AISI 316	AISI 316	1

DIMENSIONS

Size		ØD		L		E		F		G		H		W		ØA		B		ISO 5211	Weights
IN	DN	IN	MM	IN	MM	IN	MM	IN	MM	IN	MM	IN	MM	IN	MM	IN	MM	IN	MM		KG
1/4"	8	0.43	11.0	4.92	125.0	0.35	9.0	0.31	8.0	1.48	37.5	2.76	70.0	5.51	140.0	0.56	14.2	0.39	10.0	F04	1.4
3/8"	10	0.43	11.0	4.92	125.0	0.35	9.0	0.31	8.0	1.48	37.5	2.76	70.0	5.51	140.0	0.69	17.6	0.39	10.0	F04	1.3
1/2"	15	0.55	14.0	4.92	125.0	0.35	9.0	0.31	8.0	1.48	37.5	2.76	70.0	5.51	140.0	0.86	21.8	0.51	13.0	F04	1.3
3/4"	20	0.81	20.5	5.31	135.0	0.43	11.0	0.43	11.0	1.97	50.0	3.54	90.0	7.09	180.0	1.07	27.2	0.51	13.0	F04-F05	1.7
1"	25	0.98	25.0	5.91	150.0	0.43	11.0	0.43	11.0	2.36	60.0	3.94	100.0	7.09	180.0	1.33	33.9	0.59	15.0	F04-F05	2.8
1-1/4"	32	1.24	31.5	6.69	170.0	0.55	14.0	0.63	16.0	2.83	72.0	4.41	112.0	8.46	215.0	1.68	42.7	0.59	15.0	F07	3.3
1-1/2"	40	1.46	37.0	6.50	165.0	0.55	14.0	0.63	16.0	2.99	76.0	4.53	115.0	8.46	215.0	1.92	48.8	0.63	16.0	F10	5.4
2"	50	1.97	50.0	7.48	190.0	0.55	14.0	0.63	16.0	3.66	93.0	5.24	133.0	8.46	215.0	2.41	61.2	0.63	16.0	F10	8.8

SEATING SYSTEMS FOR ABRASIVE & DIRTY SERVICE COMPOSITE SEATING

Since leather was combined with timber to improve the bow, composite solutions have provided solutions for demanding applications. Yet when it comes to trunnion ball valve seats, most manufacturers only offer a single seat insert solution which is easily damaged. Service considerations include temperature, media type, pressure etc. In the end materials like Nylon, Devlon & PEEK® are a compromise that must serve many masters. Hard seat inserts have no resilience or memory for indentations and can have trouble sealing at very low pressures. In addition, these materials increase the valves torque and reduce the temperature range.

APV offers double & triple seating solutions utilising metal, teflon, hard Viton, Devlon etc. In addition we can supply special 'cam action' axial lift seats that lift off during opening & closing protecting the seat from high velocity & abrasive damage.

Seat types include:-

A-PMSS®-PRIMARY METAL SECONDARY SEAL

This design provides 'metal to metal' class IV or V shut off in addition to API 598 zero leakage provided by a resilient seat insert. This is a conventional seating design but APV optionally reduces the standard metal to metal tolerances for drip tight or bubble tight applications.

A-PMSS+S®-PRIMARY METAL SECONDARY SEAL + SCRAPER

The A-PMSS+S® design is the same as the PMSS® above except for the addition of a scraper. On conventional trunnion ball valve seating systems, APV offers the PR-A-PMSS+S® seat design option (8" and above). A protective scraper ring is inserted in front of the soft seat insert to remove solid particles, dirt or debris that could damage or clog the contact area between ball and soft seat insert ring. This feature assures that the working area of the seat will be clean allowing the seats to work effectively. This design prolongs seat life whilst only minimally increasing cost and is particularly advantageous for valves that cannot be removed from the line for repair such as butt weld valves, welded body valves, buried service valves as well as known non clean service applications.

A-DRS®-DOUBLE RESILIENT SEAL

This design marries teflon or an elastomeric seal such as hard viton which has excellent memory providing indentation resilience with Devlon, Nylon or PEEK® which handle higher pressures but are also more scratch resistant. Even with this system there is still primary metal to metal seating but it is not mate lapped like in the PMSS® Seat.

A-TRS®-TRIPLE RESILIENT SEAL

In addition to Double Resilient Seal® a third hardened Viton resilient seal is added which has more resilience to indentation & ensures a bubble tight seal even at very low pressures. This third seal will still also handle high pressures even if the other two seals fail. Many manufacturers use this as their only seal.

The above systems are ideal for applications that require redundant sealing and where access to repair the valve is not feasible. Lower torque and lower shut off pressures are additional advantages of this design.

In summary, these seating systems provide a much longer leak free life at a lower cost compared to metal to metal seated ball valves and can be supplied in quicker delivery. These seating systems offer the additional advantages of lower torque as well as high and very low pressure sealing assurance.

APV can also hard coat and treat ball and/or seat with low friction sintered coatings to reduce friction coefficient and solve wedging problems.



A-DRS® Seal

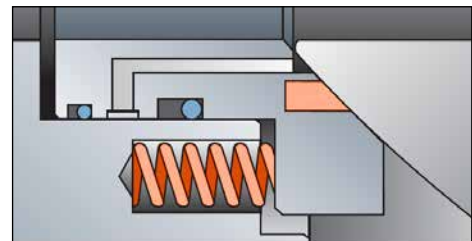

A-PMSS® Seal

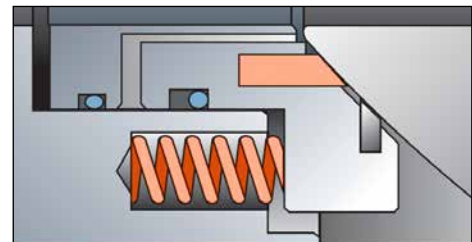

A-PMSS+S® Seal



A-DRS® Seal

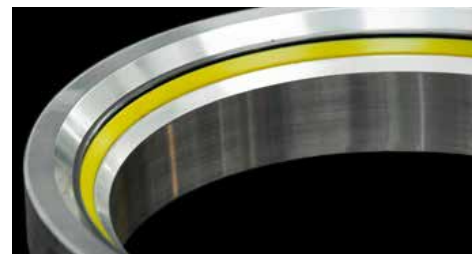

A-DRS® Seal

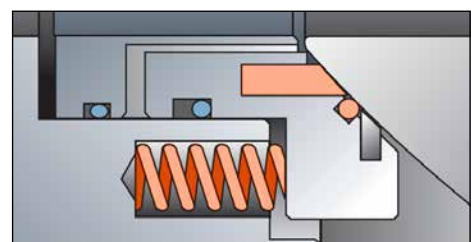

A-TRS® Seal

TOP ENTRY RISING STEM BALL VALVE OR-B150 SERIES - OVERVIEW

The **APV Rising Stem Trunnion Mounted Ball Valve** design provides true friction free operation. The valve features a mechanically set sealing feature that provides a bubble tight shutoff against liquids and gases. There is no pinch point effect to wiredraw seats or core face. The valve is designed to be inherently firesafe and incorporates an anti-blowout stem feature. The OR-B150 valve is suitable for use in petrochemical industries, liquified petroleum gas storage, refinery, natural gas, compressor system, oil and gas transportation pipelines, light industry and other industries.



FEATURES

1. Stem packing design reduces emissions through bonnet. Packing is injectable while valve is in-line.
2. In-line repairable. Top entry design provides easy repair after shutting off flow.
3. Springs which will weaken with use, are not required for sealing.
4. Mechanically energised tight seal, non lubricated, differential pressure not required for sealing, single seat design means no need for thermal relief.
5. Perpendicular movement of ball away from seat allows immediate full flow, preventing uneven erosion or abrasion of seat or ball. Also provides low torque.
6. Firesafe combination of metal and soft seat.
7. No cavity to trap product.
8. Wedge type sealing tapers at bottom of stem provide a mechanically energised and adjustable dead-tight seal at all pressure ranges. Wear resistant hard ball provides long life.

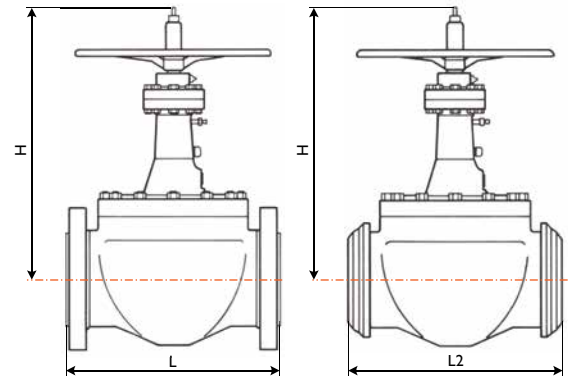

Special services easily accommodated i.e. high temperature, H2S service, low temperature etc.

CLASS 150 (mm)

DN	L	L2	H	W (Kg)
2"	178	216	381	27
3"	203	295	400	36
4"	305	368	508	82
6"	403	508	691	172
8"	457	594	778	236
10"	673	673	959	517
12"	762	762	1184	880
14"	826	826	1289	993
16"	902	991	1556	1814

CLASS 300 (mm)

DN	L	L2	H	W (Kg)
2"	216	216	381	32
3"	282	295	400	45
4"	305	368	508	91
6"	403	508	691	172
8"	502	594	778	263
10"	673	673	959	549
12"	762	762	1184	925
14"	825	826	1289	993
16"	902	991	1556	1674

CLASS 600 (mm)

DN	L	L2	H	W (Kg)
2"	292	216	381	32
3"	356	295	492	64
4"	432	368	575	118
6"	559	473	773	254
8"	660	660	933	426
10"	787	787	1238	794
12"	838	838	1348	1275
14"	889	889	1478	1583
16"	991	991	1556	1814

CLASS 900 (mm)

DN	L	L2	H	W (Kg)
2"	371	270	478	59
3"	384	337	559	77
4"	460	368	575	168
6"	613	584	870	358
8"	740	737	1202	630
10"	814	838	1326	943
12"	968	965	1508	1533

This catalogue is general in it's nature and the design and materials can change at any time. This catalogue is to be used as a guide only.

SOFT SEAT OR-B150 SERIES - SPECIFICATIONS

FEATURES

- One piece Cast Body
- Top Entry
- Rising Stem Type
- Downstream Seal
- Low Torque, Low Emission
- Long Service Life
- Reduced Bore Available
- Actuation Available
- *Orbit® style & similar



SPECIFICATIONS

- Basic Design** ASME B16.34
- Face to Face** ASME B16.10
- End Flanged** ASME B16.5
- BW End** ASME B16.25
- Test and Inspection** API 598, ISO 5208
- Manufacturing to NACE latest version on request

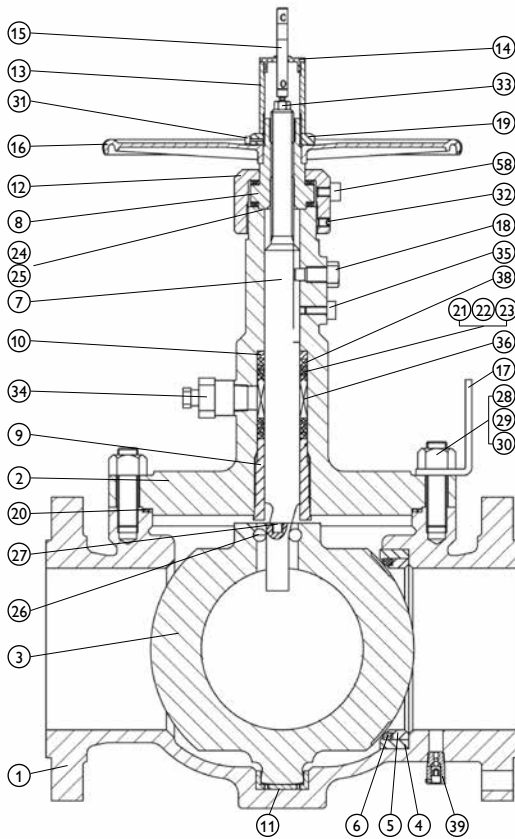

*Orbit® is a registered trademark.
 APV is not affiliated or associated with Orbit® in any way.
 The design is not the same.

MATERIALS

No.	Description	Carbon Steel		Stainless Steel Duplex	
1	Body	A216 WCC	A352 LCC	A351 CF8M	A890 4A
2	Bonnet	A216 WCC	A352 LCC	A351 CF8M	A890 4A
3	Core	A216 WCC	A352 LCC	A351 CF8M	A890 4A
4	Outside Seat	A105	A350 LF2	A182 F316	A182 F51
5	Inside Seat	A105	A350 LF2	A182 F316	A182 F51
6	Seat Insert	PTFE			
7	Stem	17-4PH			
8	Drive Nut	Cast Iron			
9	Bonnet	Stainless Steel			
10	Packing Ring	Copper			
11	Trunnion Bushing	17-4PH			
12	Gland	A216 WCC	A352 LCC	A351 CF8M	A890 4A
13	Stem Protector	Carbon Steel			
14	Rod Seal	Plastic			
15	Indicator	Stainless Steel			
16	Handwheel	Carbon Steel			
17	Lifting Lug	Carbon Steel			
18	Stem Guide	17-4PH			
19	Hex Nut	Carbon Steel			
20	Gasket	Metal & Flexible Graphite			
21	Packing	PTFE			
22	Packing	PTFE			
23	Packing	PTFE			
24	Bearing Washer	Carbon Steel			
25	Thrust Washer	Carbon Steel			
26	Core Pin	17-4PH			
27	Support Pin	Stainless Steel			
28	Bolt	A193 B7	A320 L7	A193 B8M	A193 B8MLCuN
29	Bolt	A193 B7	A320 L7	A193 B8M	A193 B8MLCuN
30	Nut	A194 2H	A194 7	A194 8M	A194 8MLCuNa
31	Screw	Stainless Steel			
32	Screw	Stainless Steel			
33	Nut	A194 2H	A194 7	A194 8M	A194 8MLCuNa
34	Stem Packing Injection	Assembly			
35	Lower Lube Fitting	Stainless Steel			
36	Packing	PTFE			
38	Graphite	Flexible Graphite			
39	Drain Fitting	Assembly			
58	Lube Fitting	Stainless Steel			

METAL SEAT OR-B150 SERIES - SPECIFICATIONS

FEATURES

- One piece Cast Body
- Top Entry
- Rising Stem Type
- Downstream Seal
- Low Torque, Low Emission
- Long Service Life
- Reduced Bore Available
- Actuation Available
- *Orbit® style & similar

SPECIFICATION

- Basic Design** ASME B16.34
- Face to Face** ASME B16.10
- End Flanged** ASME B16.5
- BW End** ASME B16.25
- Test and Inspection** API 598, ISO 5208
- Manufacturing to NACE latest version on request

MATERIALS

No.	Description	Carbon Steel	Stainless Steel
1	Body	A216 WCC	A351 CF8M
2	Bonnet	A216 WCC	A351 CF8M
3	Core	A216 WCC	A351 CF8M
4	Outside Seat	A105	A182 F316
5	Inside Seat	A105	A182 F316
6	Seat Insert	316SS	
7	Stem	Alloy Steel	
8	Drive Nut	Cast Iron	
9	Bonnet Sleeve	Stainless Steel	
10	Packing Ring	Copper	
11	Trunnion Bushing	Alloy Steel	
12	Gland	A216 WCC	A351 CF8M
13	Stem Protector	Carbon Steel	
14	Rod Seal	Plastic	
15	Indicator	Stainless Steel	
16	Handwheel	Carbon Steel	
18	Stem Guide	Alloy Steel	
20	Gasket	Metal & Flexible Graphite	
24	Bearing Washer	Carbon Steel	
25	Thrust Washer	Carbon Steel	
26	Core Pin	Alloy Steel	
27	Support Pin	Stainless Steel	
28	Bolt	A193 B7	A193 B8M
30	Nut	A194 2H	A194 8M
32	Screw	Stainless Steel	
33	Nut	A194 2H	A194 8M
39	Drain Fitting	Assembly	
50	Washer	Stainless Steel	
51	Packing Gland	A105	A182 F316
52	Packing Gland Retainer	A216 WCC	A351 CF8M
53	Packing	Flexible Graphite	
54	Packing	Inconel Wire Braided Graphite	
55	Eyebolt	A193 B7	A193 B8M
56	Nut	A194 2H	A194 8M
57	Pin	Carbon Steel	Stainless Steel

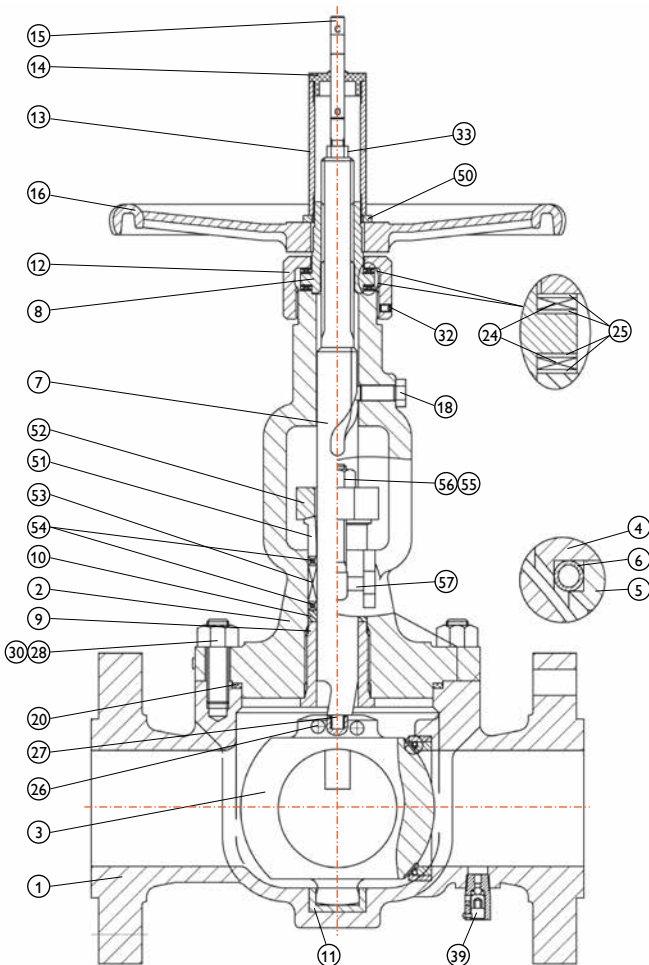

- 50NB~300NB (2" to 12") sizes.
- 150 to 1500LB
- Bonnet: Enclosed (soft seated) or OS&Y (metal seated)

*Orbit® is a registered trademark.
 APV is not affiliated or associated with Orbit® in any way.
 The design is not the same.

PIG BALL VALVES BVF100 FEP SERIES

PRODUCTION RANGE

DN 50-600 NPS 2" - 24"

PN16, 25, 40, 64, 100

ANSI Class 150, 300, 600, 900, 1500

Operation Manual, Pneumatic, Electric

Medium Water, Oil, Natural Gas, etc.

(Working Temperature) -29°C ~ +200°C



FEATURES

- Reduced space & weight requirements without expense of pigging traps
- Can retro fit in existing lines without expensive bypass modifications.
- APV Pig Valves provide a double block & bleed valve that can send or receive pigs.
- Safe, efficient, cost effective means for pigging.
- Capable of sending and receiving "Bullet", "Scraper" and "Spherical" type pigs.
- Trunnion mounted ball for extended seat life and ease of operation (all size ranges).
- Environmentally superior to Pig "T's" and Traps.
- Standard temperature range is -50°F (-46°C) to +250°F (+121°C).
- Body available in LF2, A105, WCB, 316 etc.
- Available for both sweet and sour services.
- Designed in accordance with ANSI, API, MSS and NACE requirements.

STANDARD VERSIONS



"By pass" sender version



"Shut-off" receiver version

This catalogue is general in it's nature and the design and materials can change at any time. This catalogue is to be used as a guide only.

BVF100 DOUBLE BLOCK & BLEED VALVES TWIN BALL TRUNNION DESIGN

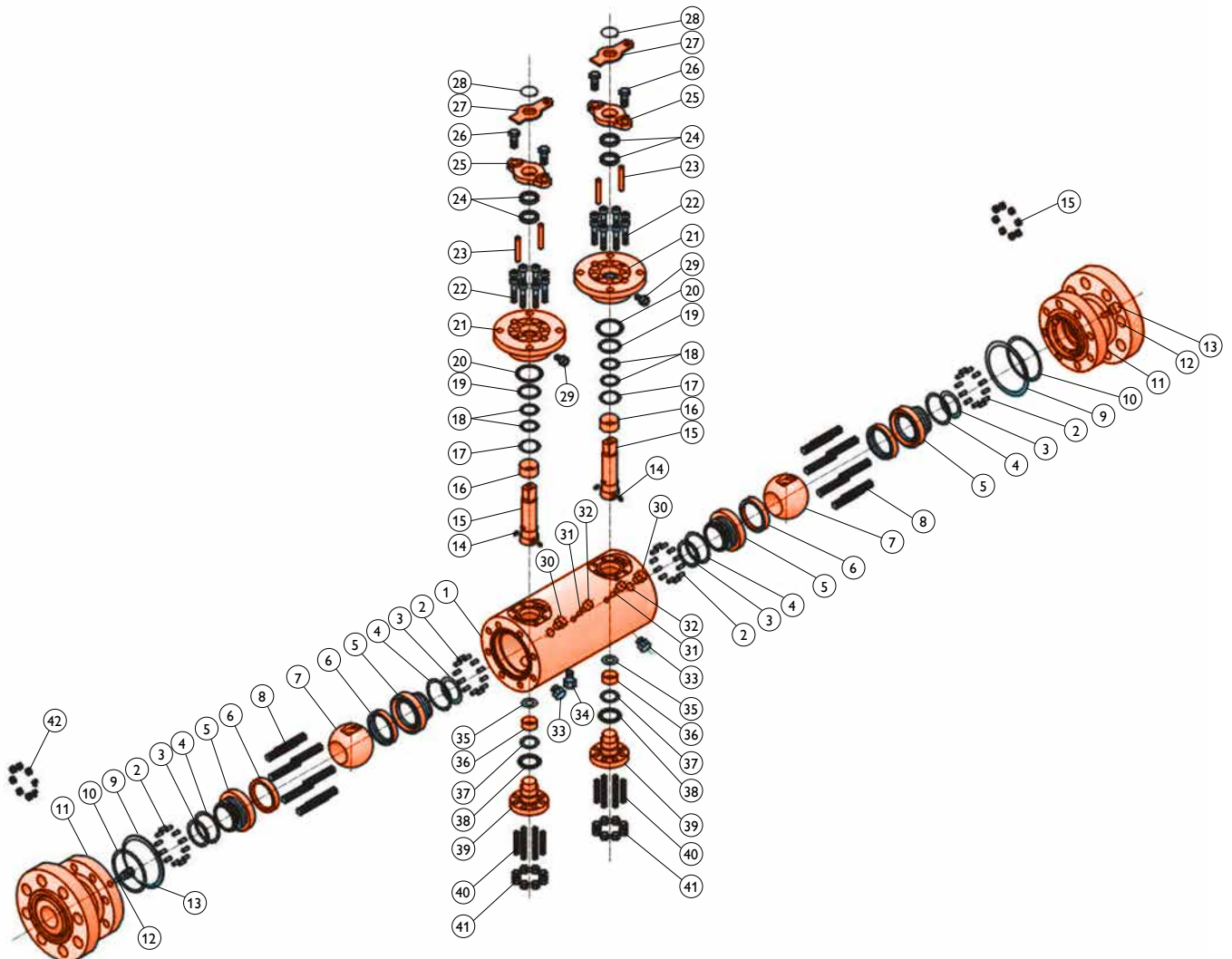

API 6FA, API 607 5th & 6th Edition
Firesafe Certified



API 622 & ISO 15848-1
Fugitive Emission Certified

BVF100 TWIN DOUBLE BLOCK & BLEED VALVES

BILL OF MATERIALS

No.	Part Name	Material				
		Carbon Steel		Stainless Steel		
1	Body	ASTM A105	ASTM A182 304	ASTM A182 316	ASTM A182 304L	ASTM A182 316L
2	Spring	INCONEL X750				
3	Firesafe packing	Graphite				
4	O-Rings	VITON	VITON	VITON	VITON	VITON
5	Seat seals	ASTM A105 + ENP	ASTM A182 304	ASTM A182 316	ASTM A182 304L	ASTM A182 316L
6	Seats	PTFE/NYLON/PEEK/PPL				
7	Ball	ASTM A105 + ENP	ASTM A182 304	ASTM A182 316	ASTM A182 304L	ASTM A182 316L
8	Studs	A193 B7M	A320 B8	A320 B8M	A320 B8	A320 B8M
9	Firesafe gasket	SST + Graphite				
10	O-Ring	VITON				
11	Tailpiece	ASTM A105	ASTM A182 304	ASTM A182 316	ASTM A182 304L	ASTM A182 316L
12	Check valve	Assembly	Assembly	Assembly	Assembly	Assembly
13	Sealant injection valve	Assembly	Assembly	Assembly	Assembly	Assembly
14	Anti-static device	Assembly	Assembly	Assembly	Assembly	Assembly
15	Stem	ASTM A182 F6a	ASTM A182 304	ASTM A182 316	ASTM A182 304L	ASTM A182 316L
16	Sliding Bearing	Metal + PTFE	Metal + PTFE	Metal + PTFE	Metal + PTFE	Metal + PTFE
17	Thrust bearing	PTFE				
18	O-Ring	VITON				
19	O-Ring	VITON				
20	Anti-fire gasket	SST + Graphite				
21	Seal gland	ASTM A105 • ENP	ASTM A182 304	ASTM A182 316	ASTM A182 304L	ASTM A182 316L
22	Socket head cap screw	A193 B7M	A320 B8	A320 B8M	A320 B8	A320 B8M
23	Pin	ANSI 1035	ANSI 1035	ANSI 1035	ANSI 1035	ANSI 1035
24	Packing	Graphite				
25	Packing gland	ASTM A216 WCB	ASTM A216 WCB	ASTM A216 WCB	ASTM A216 WCB	ASTM A216 WCB
26	Hexagon Bolt	A193 B7M	A320 B8	A320 B8M	A320 B8	A320 B8M
27	Stopper	A3 • HZn	A3 • HZn	A3 • HZn	A3 • HZn	A3 • HZn
28	Retainer ring	65Mn	65Mn	65Mn	65Mn	65Mn
29	Stem injection fitting	Assembly	Assembly	Assembly	Assembly	Assembly
30	Vent valve	Assembly	Assembly	Assembly	Assembly	Assembly
31	Check Valve	Assembly	Assembly	Assembly	Assembly	Assembly
32	Seat injection Fitting	Assembly	Assembly	Assembly	Assembly	Assembly
33	Drain Valve	Assembly	Assembly	Assembly	Assembly	Assembly
34	Drain Valve	Assembly	Assembly	Assembly	Assembly	Assembly
35	Thrust bearing	PTFE				
36	Sliding Bearing	Metal + PTFE	Metal + PTFE	Metal + PTFE	Metal + PTFE	Metal + PTFE
37	O-Ring	VITON				
38	Firesafe gasket	SST + Graphite				
39	Trunnion	ASTM A105 • ENP	ASTM A182 304	ASTM A182 316	ASTM A182 304L	ASTM A182 316L
40	Stud	A193 B7M	A320 B8	A320 B8M	A320 B8	A320 B8M
41	Hexagon nut	A194-2HM	A194-8	A194-8M	A194-8	A194-8M
42	Hexagon nut	A194-2HM	A194-8	A194-8M	A194-8	A194-8M
Design and manufacturing		API 608, API 6D				
Face-to-face dimensions		ASME B16.10, API 6D				
Type of connection		Flange	ASME B16.5/ASME B16.47		Butt Welding	ASME B16.25
Pressure test		API 598, API 6D				

Indicative of bill of material only, refer to as built drawing.

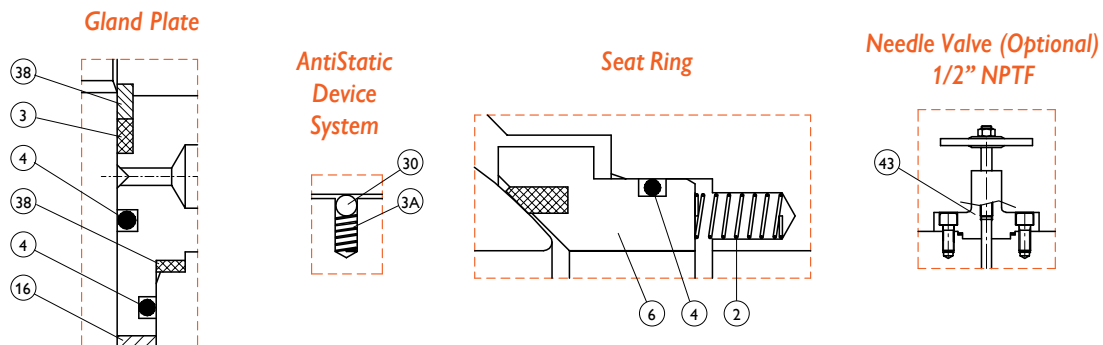

WELDED BODY TRUNNION MOUNTED BALL VALVE MODEL BVF100 CLASS 150/300

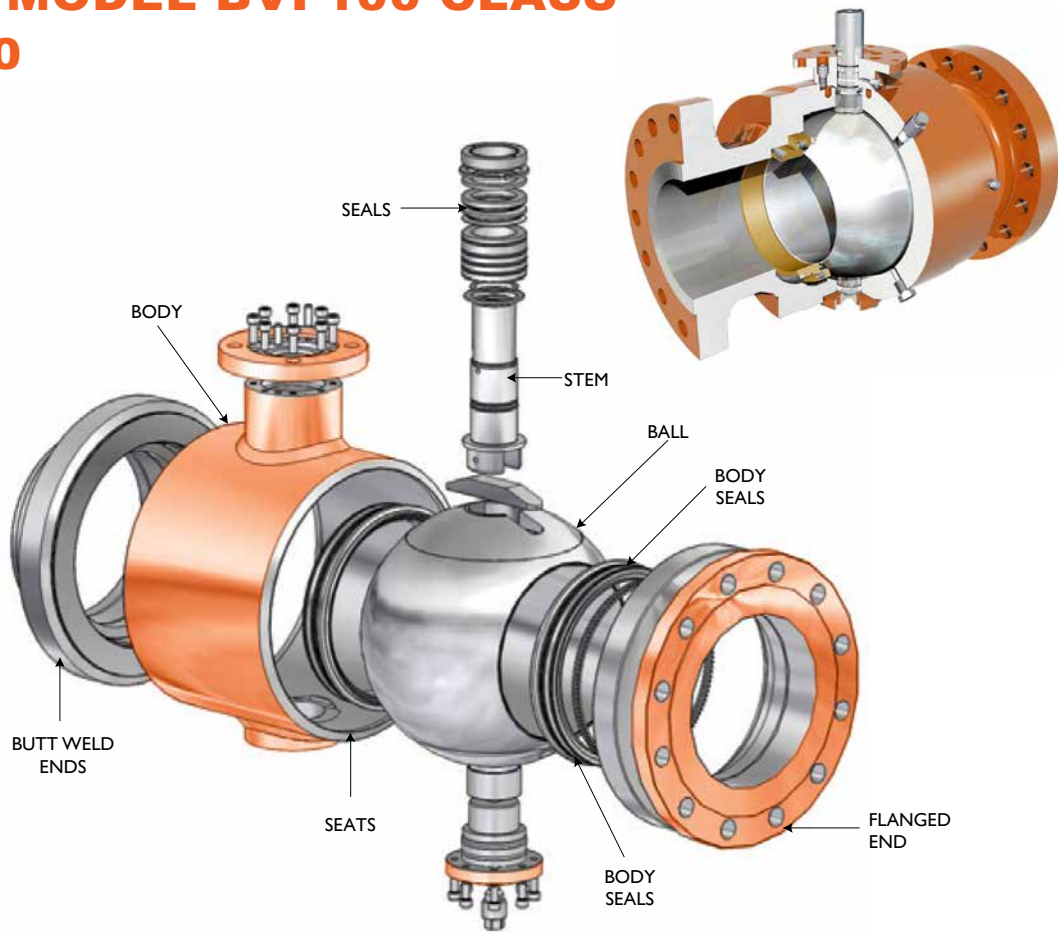

MATERIALS - 150/300 CLASS

NPS	Body	Flanged End	Butt-Weld Ends (BWE)	Ball	Stem	Back-Up Ring	Seat	Back-Up Seal	Stem Seal
1/2"									
3/4"									
1"									
1 1/4"									
1 1/2"									
2									
2 1/2"									
3"									
4"									
6"	A105N/LF2	A105N/LF2	A105N/LF2	A350 LF2 +ENP AISI 316 F51	X20Cr13 F6A 410 17-4PH F51	CS + Ni-CR SS F6A 410 F51	PTFE; PTFE+C Devlon Delrin PEEK	HNBR Viton Graphite	HNBR Viton Graphite PTFE
8"									
10"									
12"									
14"									
16"									
20"									
24"									
28"									
32"									

Example B.O.M. only. Refer to as built drawing.

WELDED BODY MODEL BVF100 - CLASS 600

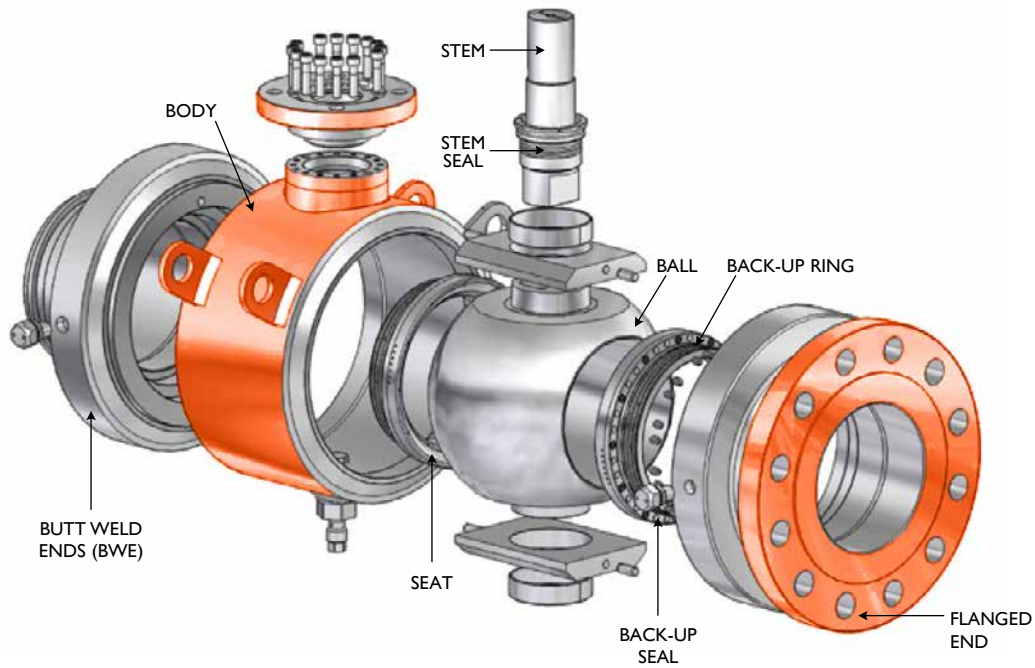

MATERIALS - 600 CLASS

NPS	BODY	FLANGED END	BUTT-WELD ENDS (BWE)	BALL	STEM	BACK-UP RING	SEAT	BACK-UP SEAL	STEM SEAL
1/2"	A105N/LF2	A105N/LF2	A105N/LF2	A350 LF2 +ENP AISI 316 F51	X20Cr13 F6A 410 17-4PH F51	CS + Ni-CR SS	PTFE; PTFE+C	HNBR Viton Graphite	HNBR Viton Graphite PTFE
3/4"									
1"									
1 1/4"									
1 1/2"									
2"									
2 1/2"									
3"									
4"									
6"									
8"									
10"									
12"									
14"									
16"									
20"									

Example B.O.M. only. Refer to as built drawing.

FORGED STEEL TOP ENTRY BALL VALVE FSTE SERIES - TRUNNION MOUNTED



Range of Material

APV's top entry ball valves have complete flexibility in the use of materials for body, trim and seal gasket selection. For this reason, they can be trimmed to meet your most severe applications.

Body/Bonnet Material

- Carbon steel
- Stainless Steel
- Duplex Stainless Steel
- Nickel Alloy
(Inconel, Incoloy, Hastelloy, Monel)

Trim Material

- Carbon steel+ (Overlay or Hard facing)
- Stainless Steel
- Duplex Stainless Steel
- Nickel Alloy
(Inconel, Incoloy, Hastelloy, Monel)

Material for Seat Inserts

Material for seat inserts are selected among the best polymers in order to meet the critical conditions of temperature, pressure and corrosive fluids.

- PTFE, PEEK, Devlon, Viton, Metal

Hard Facing options

Stellite, HVOF (TCC, CCC, others)
Self Fluxing Alloy Powder Coating (Ni Base)

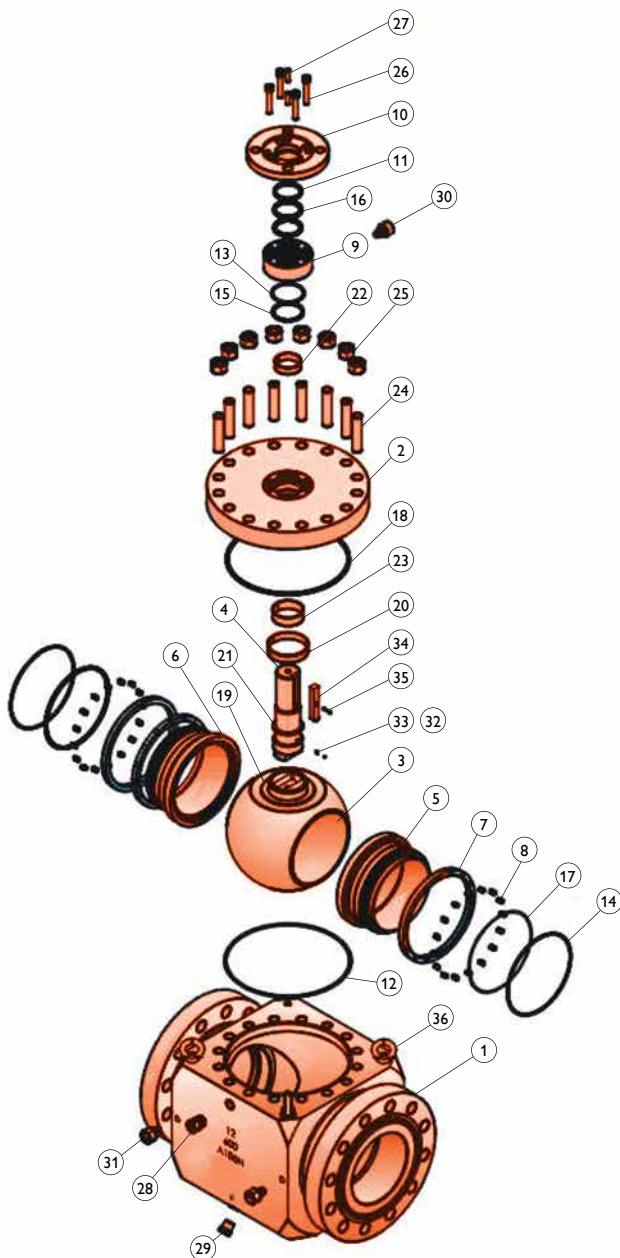

FORGED STEEL TOP ENTRY BALL VALVE

FSTE SERIES

BILL OF MATERIALS

Item	Part Name	Material	Material	Material
		A105N-316	A105N - ENP	F316
1	Body	ASTM A105N	ASTM A105N	ASTM A182 F316
2	End Adapter	ASTM A105N	ASTM A105N	ASTM A182 F316
3	Ball	ASTM A182 F316	ASTM A105N+ENP	ASTM A182 F316
4	Stem	ASTM A182 F316	ASTM A105N+ENP	ASTM A182 F316
5	Seat Ring	ASTM A182 F316	ASTM A105N+ENP	ASTM A182 F316
6	Seat Insert	RPTFE	RPTFE	RPTFE
7	Spring Plate	ASTM A182 F316	ASTM A105N+ENP	ASTM A182 F316
8	Spring	Inconel X750	Inconel X750	Inconel X750
9	Gland	ASTM A105N	ASTM A105N	ASTM A182 F316
10	Gland Plate	ASTM A105N	ASTM A105N	ASTM A182 F316
11	Stem Packing	Graphite	Graphite	Graphite
12	Anti-fire Gasket	SW.316+Graphite	SW.316+Graphite	SW.316+Graphite
13	Anti-fire Gasket	SW.316+Graphite	SW.316+Graphite	SW.316+Graphite
14	O-ring	Viton	Viton	Viton
15	O-ring	Viton	Viton	Viton
16	O-ring	Viton	Viton	Viton
17	O-ring	Viton	Viton	Viton
18	O-ring	Viton	Viton	Viton
19	Ball Thrust Bearing	AISI 1045 + PTFE	AISI 1045 + PTFE	AISI 1045 + PTFE
20	Ball DU Bearing	AISI 1045 + PTFE	AISI 1045 + PTFE	AISI 1045 + PTFE
21	Stem Thrust Bearing	AISI 1045 + PTFE	AISI 1045 + PTFE	AISI 1045 + PTFE
22	Stem DU Bearing	AISI 1045 + PTFE	AISI 1045 + PTFE	AISI 1045 + PTFE
23	End Adapter DU Bearing	AISI 1045 + PTFE	AISI 1045 + PTFE	AISI 1045 + PTFE
24	Body Stud	ASTM A193 B7	ASTM A193 B7	ASTM A193 B8
25	Body Nut	ASTM A194 2H	ASTM A194 2H	ASTM A194 8
26	Gland Screw	ASTM A193 B7	ASTM A193 B7	ASTM A193 B8
27	Pin	AISI 1045	AISI 1045	AISI 1045
28	Vent Valve	ASTM A105N	ASTM A105N	ASTM A182 F316
29	Plug	SS316	SS316	SS316
30	Sealant Injection Fitting Assembly	ASTM A105N	ASTM A105N	ASTM A182 F316
31	Sealant Injection Fitting Assembly	ASTM A105N	ASTM A105N	ASTM A182 F316
32	Anti-static Ball	SS316	SS316	SS316
33	Anti-static Spring	SS316	SS316	SS316
34	Key	SS316	SS316	SS316
35	Spring Pin Slotted	SS316	SS316	SS316
36	Lug	Carbon Steel	Carbon Steel	Carbon Steel

Indicative only, refer to as built drawing

FSTE / CSTE SERIES - DIMENSIONS

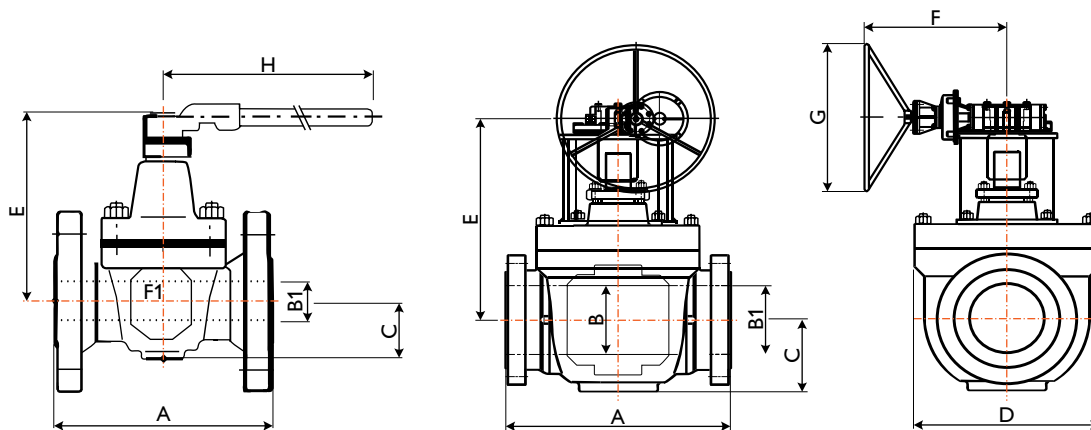

ANSI CLASS 1500

Size	A			B	B1	C	D	E	F	G	H1	WGT
	RF	RTJ	WE									
2X1 1/2	368	371	368	38	51	85	205	450	-	-	-	75
2	368	371	368	51	51	85	205	600	-	-	-	80
3X2	470	473	470	51	77	85	205	600	-	-	-	95
3	470	473	470	77	77	120	250	1000	-	-	-	130
4X3	546	549	546	77	102	120	250	1000	-	-	-	180
4	546	549	546	102	102	155	310	295	340	700	-	270
6X4	705	711	705	102	146	155	310	295	340	700	-	340
6	705	711	705	146	146	240	370	333	545	700	-	635
8X6	832	841	832	146	194	240	370	333	545	700	-	770
8	832	841	832	194	194	280	455	410	575	700	-	1150
10X8	991	1000	991	194	241	280	455	410	575	700	-	1500
10	991	1000	991	241	241	340	565	460	575	700	-	1610
12X10	1130	1146	1130	241	289	340	565	460	575	700	-	2120
14X10	1257	1276	1257	241	317	340	565	460	575	700	-	2190
12	1130	1146	1130	289	289	400	670	511	575	700	-	2750
16X12	1384	1406	1384	289	362	400	670	511	575	700	-	3250
14	1257	1276	1257	317	317	467	730	575	579	700	-	3400
16	1384	1406	1384	362	362	495	790	620	579	700	-	5250
18	1537	1559	1537	407	407	520	840	740	950	1400	-	6300
20	1664	1686	1664	457	457	639	965	795	950	1400	-	7900
24	2043	2071	2043	534	534	640	1145	979	1045	1400	-	12500
30	2590	2610	2590	688	688	1350	1750	-	-	-	1250	30000
32	2770	2790	2770	732	732	1500	1900	-	-	-	1300	35000
36	3110	3130	3110	821	821	1800	2200	-	-	-	1400	50000

ANSI CLASS 2500

Size	A			B	B1	C	D	E	F	G	H1	WGT
	RF	RTJ	WE									
2X1 1/2	451	454	451	38	44.5	93	250	600	-	-	-	96
2	451	454	451	44.5	44.5	105	270	250	297	300	-	130
3X2	578	584	578	44.5	63.5	105	270	250	297	300	-	175
3	578	584	578	63.5	63.5	127	350	305	340	700	-	260
4X3	673	683	673	63.5	89	127	350	305	340	700	-	340
4	673	683	673	89	89	156	400	360	340	700	-	485
6X4	914	927	914	89	133	156	400	360	340	700	-	790
6	914	927	914	133	133	240	480	430	575	700	-	1410
8X6	1022	1038	1022	133	181	240	480	430	575	700	-	2100
8	1022	1038	1022	181	181	280	530	513	575	700	-	2550
10X8	1270	1292	1270	181	226	280	530	513	575	700	-	2950
10	1270	1292	1270	226	226	365	720	620	590	700	-	3400
12X10	1422	1445	1422	226	267	365	720	620	590	700	-	3980
12	1422	1445	1422	267	267	430	860	740	505	620	-	4600

• Dimensions in mm • All weights in kg are approximate

CAST STEEL TOP ENTRY BALL VALVE CSTE - K1F SERIES FLOATING BALL CLASS 150/300

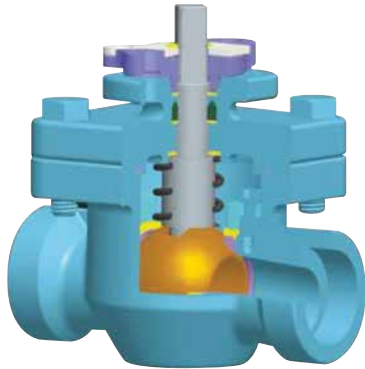

DESIGN FEATURES

- Top Entry, Floating Ball
- Body-cover Bolted joint not affected by Pipe stress
- Firesafe, blow-out proof and Anti-static stem
- Tight shut-off and long cycle life
- Permits In-line access for seat replacement
- Welding into line possible without disassembly
- Mechanically energised seat
- Flanged, BW, SW, NPT ends



Flanged Ends



SW, NPT Ends



Buttweld Ends



Steam Jacketed

CAST STEEL TOP ENTRY BALL VALVE CSTE - K1F SERIES FLOATING BALL

APPLICABLE STANDARDS

- Design** ASME B16.34
- Wall Thickness** ASME B16.34
- Flanged Ends** ASME B16.5
- Extended Butt Weld** ASME B16.25
- Inspection & Testing** API 598, API 6D

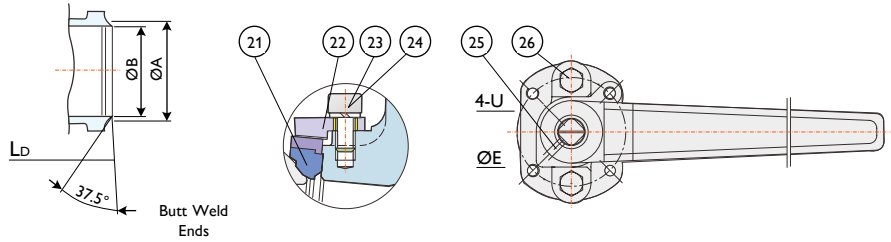

BILL OF MATERIALS

No	Part Name	Materials	
1	Body	CF8M	CF8 WCB
2	Handle Gland	316	304
3	Cap	CF8M	CF8 WCB
4	Body Gasket	PTFE/GRAFOIL*	
5	Ball	CF8M	CF8
6	Stem	316	304/A182-F6a
7	Spring	316	304
8	Adjusting Gasket	316	304
9	Guiding Bushing	316	304
10	Thrust Washer	PTFE	
11	Stem Packing	PTFE/GRAFOIL*	
12	Stem Gasket	316	304
13	Stem Bushing	PTFE	
14	Snap Ring	304	
15	Handle	WCB	
16	Stop-Lock-Plate	304	
17	Gland Packing	304	
18	Bolting	A193-B8	A193-B7
19	Nut	A194-8	A194-2H
20	Protection Cover	PVC	
21	Ball Seat	TFM1600+316 Outer Ring	
22	Gland	316	304
23	Hex. Bolting	A193-B8M	A193-B8
24	Spring Washer	316	304
25	Screw	A193-B8	
26	Bolt	A193-B8	A193-B7

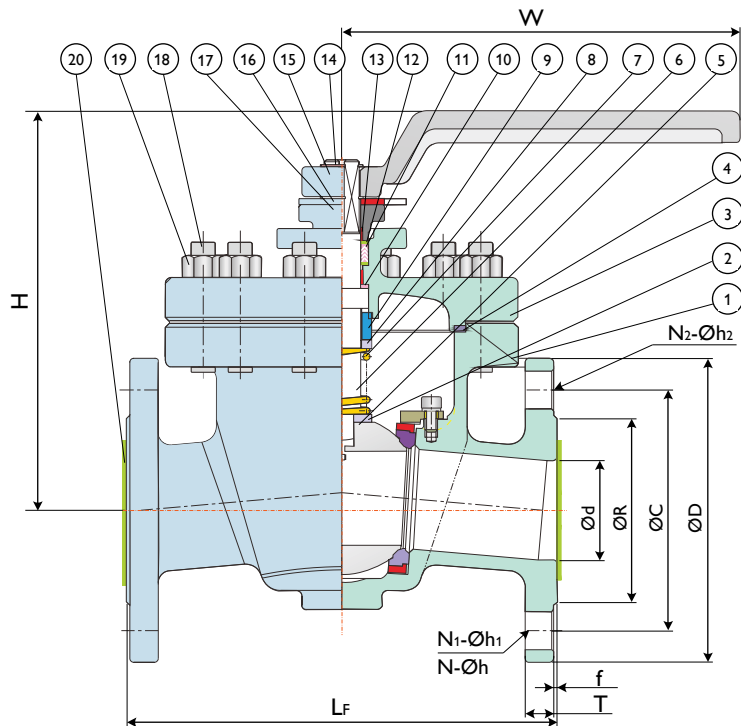

ASME CLASS 150

(MM)

Size	W	LF	LD	d	R	D	C	f	T	H	N1	h1	N2	h2	E	U	B	A
DN15 1/2"	130	108	140	15	35.0	90	60.3	2	8	120	4	16.0	-	-	42	M5	-	-
DN20 3/4"	130	117	152	20	43.0	100	69.9	2	8.9	120	4	16.0	-	-	42	M5	-	-
DN25 1"	160	127	165	25	51.0	110	79.4	2	9.6	130	2	16.0	2	1/2-13UNC	50	M6	-	-
DN32 1-1/4"	160	140	178	32	63.5	115	88.9	2	11.2	134	2	16.0	2	1/2-13UNC	50	M6	-	-
DN40 1-1/2"	200	190	190	38	73.2	130	98.4	2	12.7	175	4	16.0	-	-	70	M8	-	-
DN50 2"	200	216	216	50	92.0	150	120.7	2	14.3	200	4	19.0	-	-	70	M8	-	-
DN80 3"	265	282	356	76	127.0	190	152.4	2	17.5	214	4	19.0	-	-	102	M10	78	88.9
DN100 4"	325	432	432	100	157.2	230	190.5	2	22.3	250	8	19.0	-	-	102	M10	102	114.3
DN150 6"	800	457	457	150	216.0	280	241.3	2	23.9	350	8	22.3	-	-	125	M12	154	168.3

ASME CLASS 300

(MM)

Size	W	LF	LD	d	R	D	C	f	T	H	N	h	E	U	B	A
DN15 1/2"	130	140	140	15	35.0	95	66.7	2	12.7	120	4	16.0	42	M5	-	-
DN20 3/4"	130	152	152	20	43.0	115	82.6	2	14.3	120	4	19.0	42	M5	-	-
DN25 1"	160	165	165	25	51.0	125	88.9	2	15.9	130	4	19.0	50	M6	-	-
DN32 1-1/4"	160	178	178	32	63.5	135	98.4	2	17.5	137	4	19.0	50	M6	-	-
DN40 1-1/2"	200	190	190	38	73.2	155	114.3	2	19.1	175	4	22.3	70	M8	-	-
DN50 2"	200	216	216	50	92.0	165	127.0	2	20.7	200	8	19.0	70	M8	-	-
DN80 3"	265	282	356	76	127.0	210	168.3	2	27.0	214	8	22.3	102	M10	78	88.9
DN100 4"	325	432	432	100	157.2	225	200.0	2	30.2	250	8	22.3	102	M10	102	114.3
DN150 6"	800	457	457	150	216.0	320	269.9	2	35.0	350	12	22.3	125	M12	154	168.3



AUSTRALIAN PIPELINE VALVE®

COMPLETE PRODUCT LINE

“Australian Pipeline Valve produces isolation, control and flow reversal protection products for severe and critical service media in utility, steam, pipelines, oil & gas and process industries. APV valves and pipeline products form the most competitive portfolio in the market.”



SUPER-CHECK®



TORQTURN®

TWIN-LOK®

UNIFLO®



AUSTRALIAN PIPELINE VALVE BRAND RANGE - CATALOGUES

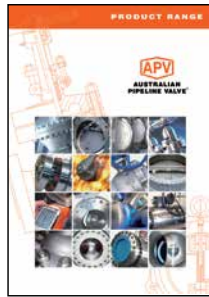

Product Brochure



Ball Valves Floating & Trunnion Mounted

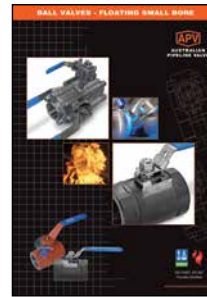

Ball Valves Floating Small Bore

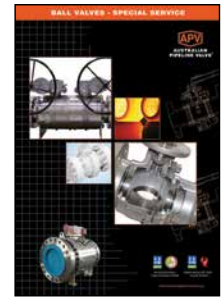

Ball Valves Special Service



Gate, Globe & Check Valves - Cast Steel



Gate, Globe & Check Valves - Forged Steel

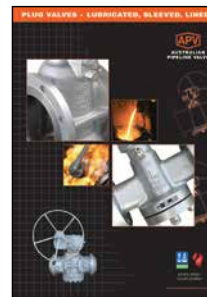

Plug Valves Lubricated, Sleeved & Lined

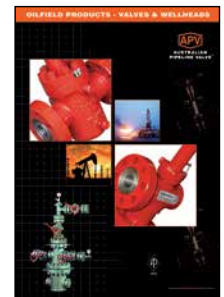

Oilfield Products - Valves & Wellheads

APV FAMILY OF BRANDS RANGE - CATALOGUES



Diamond Gear Gearboxes

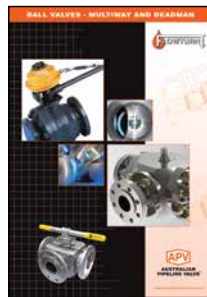

Flowturn Ball Valves Multiway & Deadman



Flowturn Gate, Globe & Check Valves



Flowturn Instrument Valves



Flowturn Strainers & Sight Glasses



Steamco Steam Valves



Supercheck Wafer Check Valves



Superseal Butterfly Valves



Superseal Industrial Ball Valves



Torqturn Actuators

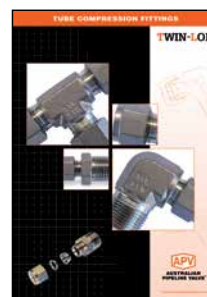

TwinLok Tube Fittings

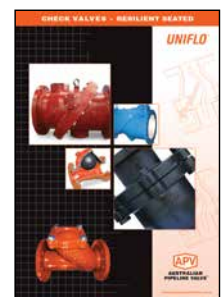

Uniflo Check Valves

Contact us for your local stockist/distributor



AUSTRALIAN PIPELINE VALVE®

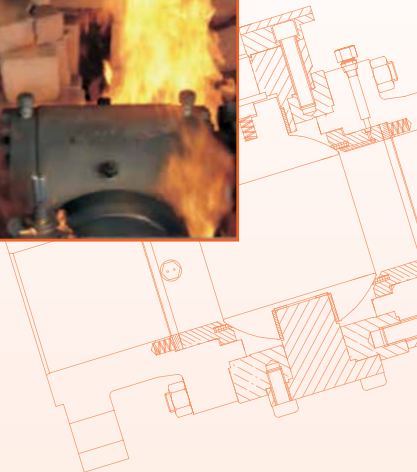

www.australianpipelinevalve.com.au

LOCAL DISTRIBUTOR



QUALITY ASSURANCE AND CERTIFICATION

We are continually improving all facets of quality assurance. Full metallurgical and test certificates are always supplied for all pressure retaining parts, we also provide it on all major trim components.

We have endeavoured to provide a broad outline of our range and capabilities. Because we are continually developing new products for our customers this catalogue will, to some extent be incomplete. This catalogue is a general overview only, individual drawings and data sheets can be furnished on request.

If you have any requirement in the field of valves, please contact us for a prompt response. Continuous development of Australian Pipeline Valve products may necessitate changes in the design or manufacturing processes. Australian Pipeline Valve reserves the right to effect any such changes without prior notice.

