

CHECK VALVES - WAFER STYLE

SUPER·CHECK

SHORT VERSION

[Click here](#) for complete version of this catalogue

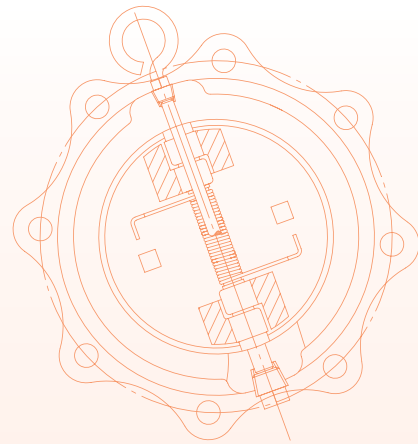

Firesafe Certified



**AUSTRALIAN
PIPELINE VALVE®**

www.australianpipelinevalve.com.au

QUALITY VALVE MANUFACTURER

QUALITY COMMITMENT

Quality is Our First Priority.

Consistent product quality and a proven track record makes Australian Pipeline Valve a dependable choice where total reliability is the number one concern.

Since its founding, APV's philosophy has been focused on quality. Our valves are manufactured in full compliance to worldwide standards (such as ASME/ANSI, API, EN, ISO, BS, AS).

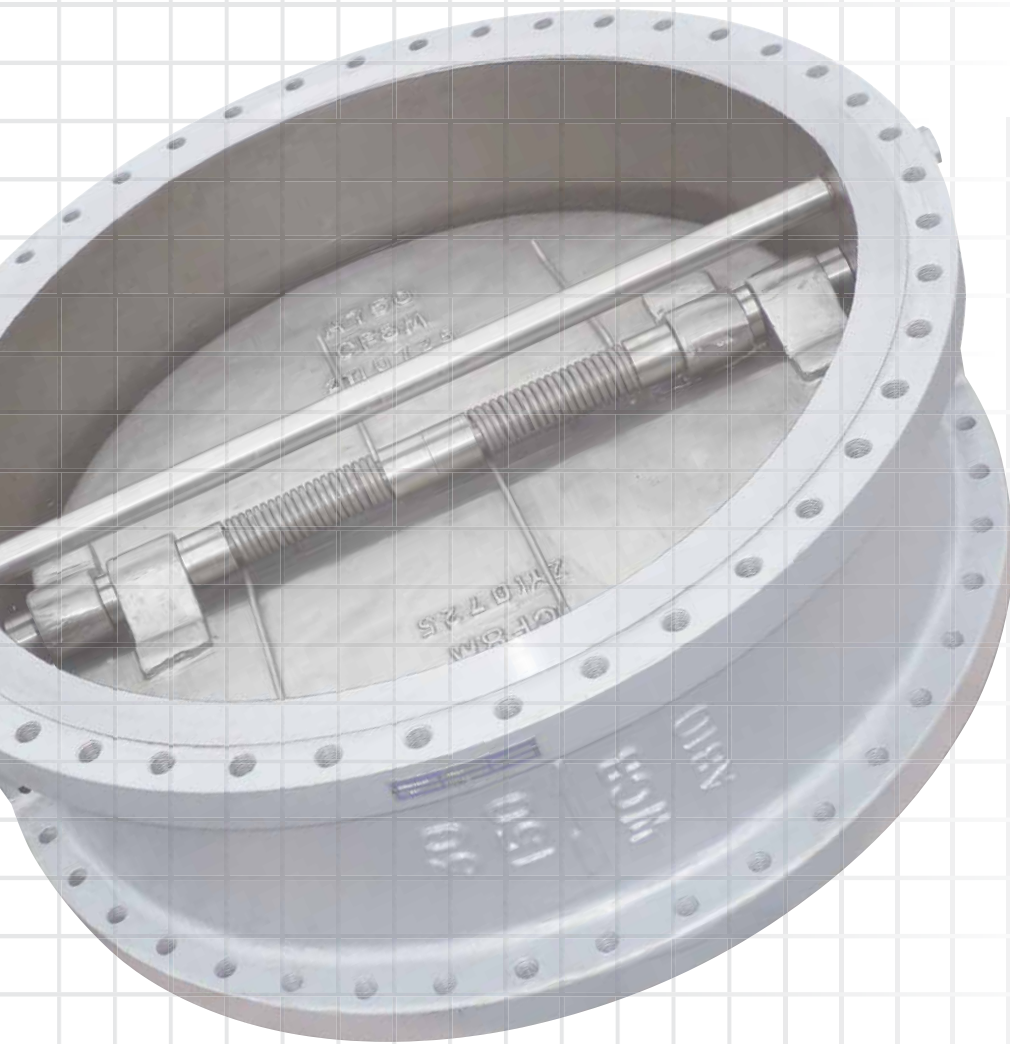

**AUSTRALIAN
PIPELINE VALVE®**

70-78 Stanbel Road Salisbury Plain South Australia 5109
Telephone +61 (0)8 8285 0033 Fax +61 (0)8 8285 0044
email: admin@australianpipelinevalve.com.au

www.australianpipelinevalve.com.au

CONTENTS - SHORT VERSION*

Wafer Check Dual Flap Iron Body ASG Series	4~5*
Wafer Check Dual Flap Steel Body ASG Series	6~16*
Wafer Check Dual Flap Steel Body AGW Series	17~28*
ASG / AGW Part Number System	29
Wafer Check Dual Flap TUF-SKIN	30
Wafer Check Single Flap Long Pattern SLP/SW Series	31~34
Wafer Check Single Flap Lined Long Pattern DO Series	35~36*
Wafer Check Super-Lite Model 2024	37~38*
Wafer Check Non Slam Axial Disc Model NSSLSC	39~40
Wafer Check Threaded In-Line Model R-APSC-V	41~42*
Non Slam Nozzle Check Valve	43~45*

* This version excludes some of these pages, refer to full version at website.



API 6FA-5th
Firesafe Certified



© Copyright Australian Pipeline Valve 1990 - 2022 Edition

Catalogues, photos, brochures and technical publications are the exclusive property of Australian Pipeline Valve. Any unauthorised reproduction in total or in part, shall result in prosecution. Products and data sheets in this publication are subject to change at anytime without notice. Australian Pipeline Valve reserves the right to carry out amendments to products and materials.

WAFER CHECK DUAL FLAP IRON BODY ASG SERIES (IRON)

125LB, PN10, PN14 & PN16 RATED

- Rating** API 594 - Class 125/150 or AS/EN/ISO/BS PN10/PN14/PN16
- Design** API 594, BS/EN 16767
- Max temp** -18°C* to 100°C Buna - N, -18°C* to 110°C EPDM, -18°C* to 121°C metal seat (As Body).
- Flanging** To suit ASA 125, 150, EN1092-2 PN10/PN16, AS2129 Table D, E, AS4087 PN14/PN16/PN21, ISO 7005-1 PN10/PN16, AS4331.1 PN10/PN16, EN 1092-2 PN10/PN16, JISB 2220 5K~20K
- Face to Face** EN 558 (was DIN 3203-K3), BS/EN 16767 or EN 16782 (3202-K3) or ASME B16
- Test** API 598/ISO 5208/MSS SP67-1
- Metal seated leakage** 3CC/min/inch of valve size per API 598.
- Soft seated** leak tight shut off.

* Iron body limitation -18°C

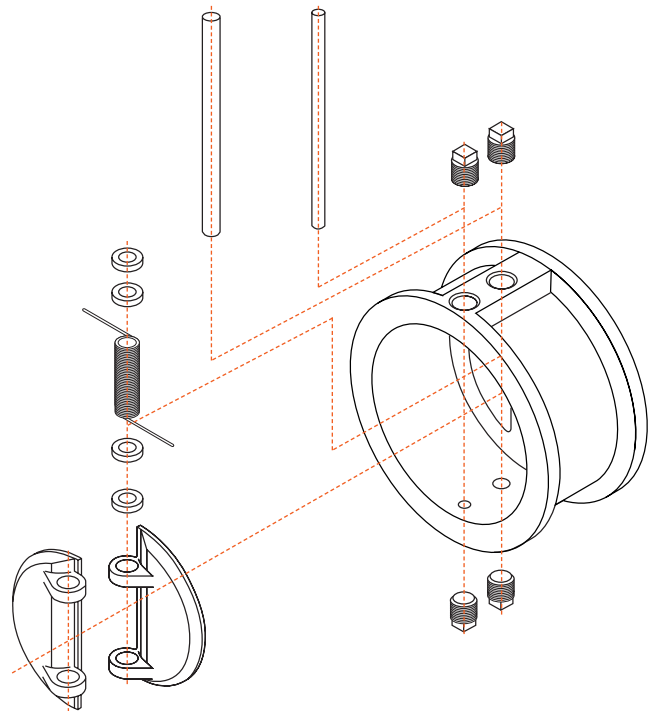

DESIGN FEATURES

- **Encapsulated and bonded body seat (soft seat)**
- **Upper and lower PTFE thrust bearings**
- **Dual springs for quicker activation long life and even distribution of force over both plates**
- **Fusion bonded epoxy coated body (internal & external)**
- **Long leaf springs (prevent rubbing of disc and seat)**
- **Alleviation from Water Hammer**
Reaction of torsion spring makes plates rapidly close prior to the start of reverse flow of fluid due to the stop of power, thus prevents damage from water, hammering caused by pumps and other reciprocating devices.
- **Lower Head Loss**
Designed with optimum venturi to reduce head loss when compared with similar Dual Plate Type Check Valves.
- **Installation Directions**
In addition to the compact size, SUPER-CHECK valves can be installed either horizontally or vertically.
- **Long Leg Torsion Spring**
Action which allows the plates to open and close without seat scrubbing.
- **Super-Check** provide a complete range of sizes from ND 40 through ND 1800, designed and rated in accordance with ANSI 125 LB, PN10, PN14, PN16, PN21

BILL OF MATERIALS

	Part Name	Materials
1	Body	Iron 126 Class B, Ductile Iron+FBE
2	Plate	Bronze, 304SS, 410SS, 316SS, Duplex, iron
3	Springs (Long Leg)	316SS
4	Pin	304SS or 316SS
5	Body Seat	NBR (BUNA), EPDM, Viton, Metal
7	Bearing	PTFE
9	Retainer	S25C or S/S
10	Eye Bolt	SS41
11	O-Ring	Viton, NBR, EPDM



SLIM PLATE DESIGN

Standard in all sizes. Ensures lower cracking pressures & large flow rates.

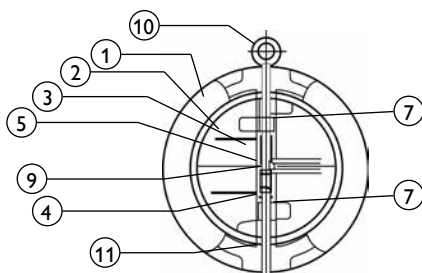

IMPORTANT

Ensure the valve is at least eight pipe diameters from reciprocating or pulsating devices.



ASG SERIES (IRON)

NON-SLAM

SUPER-CHECK is a non-slam check valve because it operates on flow cessation, not flow reversal. The normal position of the plates is closed, held against the seat by the unique spring design. As flow begins, the heels of the two plates are lifted off the seat face on the central rib.

This cracking pressure is less than 14 kPa (2 psi) across most of the range (larger sizes can be more). As flow increases, the plates then pivot against the spring pressure. Since the heels have already lifted off the seat there is no scrub or wear, either on the seat, body or plate seating surfaces. A pressure of only 28 kPa (4 psi) is required to keep the plates fully open (up to 400 NB).

When flow stops and the pressure ceases, the spring closes the plates. Flow reversal is then stopped by the closed Supercheck valve and in fact any back pressure only serves to make the valve seal more tightly.

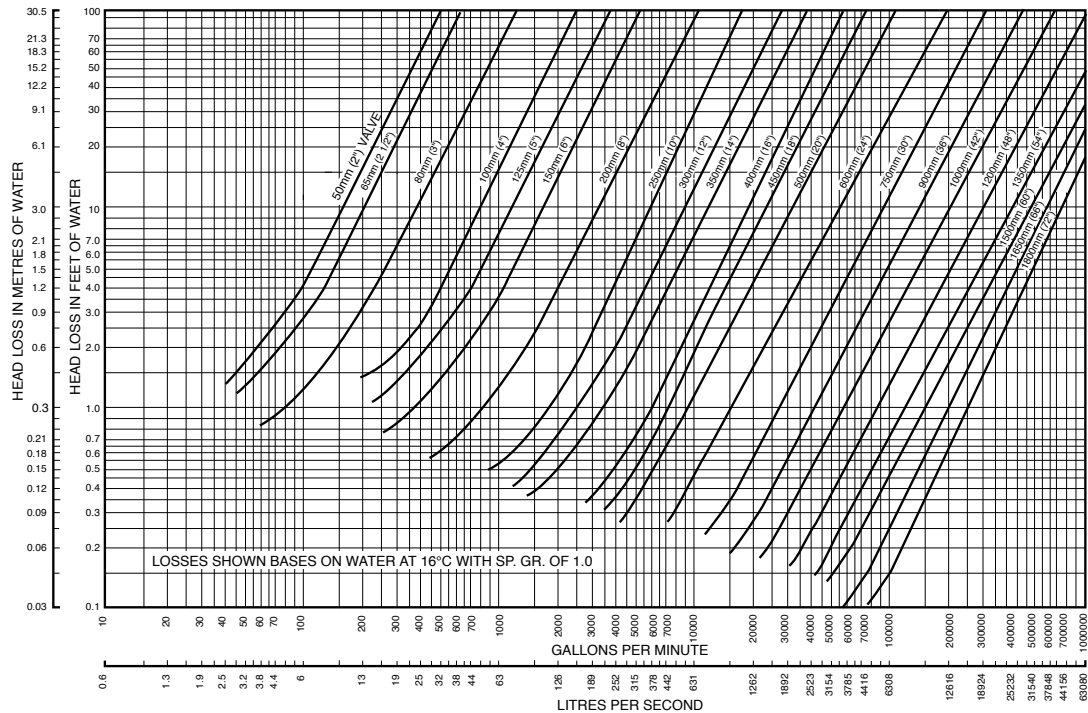

DIMENSIONS (To suit ASA125 & AS Table D/E PN14/PN16 Flanging)

mm	Inch	Suit Flanging	Facing	Dimensions					Weight (Kgs)
				øA	B	C	D	G ^R	
50	2"	AST-D/E, PN14/PN16*	FF	98	43	60	26	32	3
		125**	FF	105	54	60	26	32	4
65	2 1/2"	AST-D/E, PN14/PN16*	FF	111	46	73	26	37	4
		125**	FF	124	54/60	73	26	37	5
80	3"	AST-D/E, PN14/PN16*	FF	130	57/64	89	28	45	5
		125**	FF	137	57/67	89	38	45	6
100	4"	AST-D/E, PN14/PN16*	FF	162	64	114	31	53	6
		125**	FF	175	64/67	114	31	53	8
125	5"	AST-D/E, PN14/PN16*	FF	194	70	141	32	67	9
		125**	FF	197	70/83	141	32	67	10
150	6"	AST-D/E, PN14/PN16*	FF	213	76	168	31	79	10
		125**	FF	222	76/95	168	31	79	16
200	8"	AST-D/E, PN14/PN16*	FF	272	89	219	38	105	19
		125**	FF	279	95/127	219	38	105	30
250	10"	AST-D/E, PN14/PN16*	FF	333	108	274	43	123	31
		125**	FF	340	108/140	274	43	123	45
300	12"	AST-D/E, PN14/PN16*	FF	381	114	324	59	155	56
		125**	FF	410	143/181	324	69	153	80
350	14"	AST-D/E, PN14/PN16*	FF	445	127	356	78	170	71
		125**	FF	451	184	356	94	170	83
375	15"	AST-D/E, PN14/PN16*	FF	471	140	406	89	195	99
		125**	FF	496	140	406	89	195	99
450	18"	AST-D/E, PN14/PN16*	FF	514	191	406	89	195	116
		125**	FF	560	152	457	86	219	118
500	20"	AST-D/E, PN14/PN16*	FF	549	203	457	86	219	143
		125**	FF	617	152	508	89	244	160
600	24"	AST-D/E, PN14/PN16*	FF	606	213	508	89	244	180
		125**	FF	726	178	610	87	300	230
				718	222	610	87	292	261

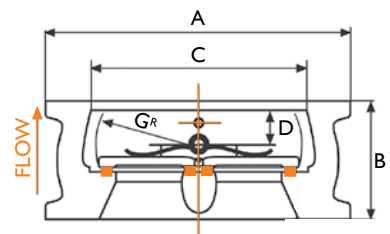
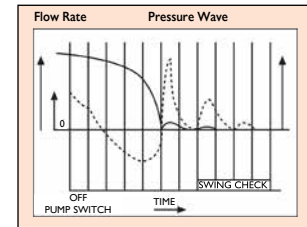
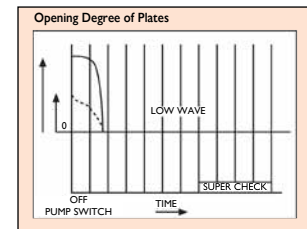

* Rated PN16 multi-fit AS 2129 Table D & E, AS 4087 PN14 & PN16.
 ** Refer to API 594/ASME B16.10/API 6D short or AWWA C518 (Different)

WAFER CHECK DUAL FLAP STEEL BODY ASG SERIES

CHARACTERISTICS

- High performance non slam
- Face to face to API 594, wall thickness & design to API 594, test & inspection to API 598 flanging to ASME B16.5
- Vertical or Horizontal installation.
- Intrinsically Firesafe
- Very low head loss & minimum occupation of space
- Suitable to fit between ANSI 150, 300, 600, 900, 1500 & 2500 flanges as well as API, BS, AS, JIS, ISO, EN etc.
- Can be mounted horizontal or vertically
- Service Pressure
 - 150 class 20 Bar (285 PSI)
 - 300 class 51.1 Bar (740 PSI)
 - 600 class 102.1 Bar (1480 PSI)
 - 900 class 153.2 Bar (2220 PSI)
 - 1500 class 255.3 Bar (3705 PSI)
 - 2500 class 425.5 Bar (6170 PSI)
- Tight shut-off (resilient seat).
Metal seat 50% lower leakage than API 598 allows.



API 6FA-5th
Firesafe Certified



DESIGN FEATURES

- **Alleviation from Water Hammer**
Reaction of torsion spring makes plates rapidly close prior to the start of reverse flow of fluid due to the cessation of power, thus preventing pump and other devices from causing damage due to Water Hammering.
- **Lower Head Loss**
Designed with optimum venturi to reduce head loss and is comparable with similar Duo-check Dual Plate type Check Valves.

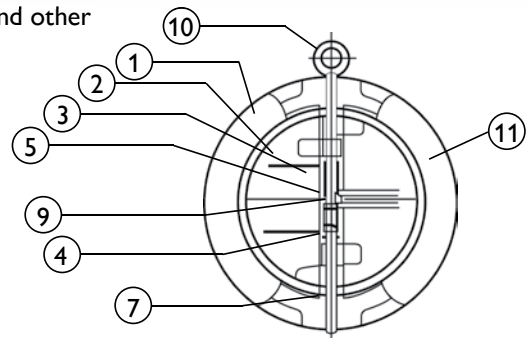

COMMON TRIM (WETTED PARTS) CONFIGURATIONS†

Body (1)	Plates (2)	Seat (11)	Spring (3)	Stop (5) & Hinge Pins (4)	Body plate & Spring Bearings (7/9)
WCB	WCB / CR13 / 304 / 316	Viton	316 or Inconel	316 SS / CR13	316 SS
WCB	WCB / CR13 / 304 / 316	Metal*	316 or Inconel	316 SS / CR13	316 SS
WCB	WCB / CR13 / 304 / 316	Viton	316 or Inconel	316 SS / CR13	316 SS
WCB	WCB / CR13 / 304 / 316	Buna-NBR	316 or Inconel	316 SS / CR13	316 SS
CF8 (304 SS)	304 SS	Buna-NBR	304 or Inconel	304 SS	316 SS
CF8 (304 SS)	304 SS	Metal*	316 or Inconel	316 SS	316 SS
CF8 (304 SS)	304 SS	Viton	316 or Inconel	316 SS	316 SS
CF8M (316 SS)	316 SS	Metal	316 or Inconel	316 SS	316 SS
CF8M (316 SS)	316 SS	Viton	316 or Inconel	316 SS	316 SS

* Seat types - As per body, ST#6, HF, CR13, 316

† For other available trim configurations refer part number system.

ASG SERIES

INSTALLATION

In addition to the compact shape, SUPER-CHECK Valves can be installed either horizontally or vertically.



NON-SLAM

SUPERCHECK is a non-slam check valve because it operates on flow cessation, not flow reversal.

The normal position of the plates is closed, held against the seat by the unique spring design. As flow begins, the heels of the two plates are lifted off the seat face on the central rib.

The cracking pressure is less than 21 kPa (3 psi) across most of the range (larger sizes and higher classes proportionately are slightly higher). As flow increases, the plates then pivot against the spring pressure.

Since the heels have already lifted off the rib seat there is no scrub or wear, either on the rib, body or plate seating surfaces. A pressure of only 27 kPa (4 psi) is required to keep the plates fully open in 150 class, proportionately higher in other classes and larger sizes. ("Light" springs also available) When flow stops and pressure ceases the spring closes the plates. Flow reversal is then stopped by the closed Supercheck valve and any back pressure only serves to make the valve seal more tightly.

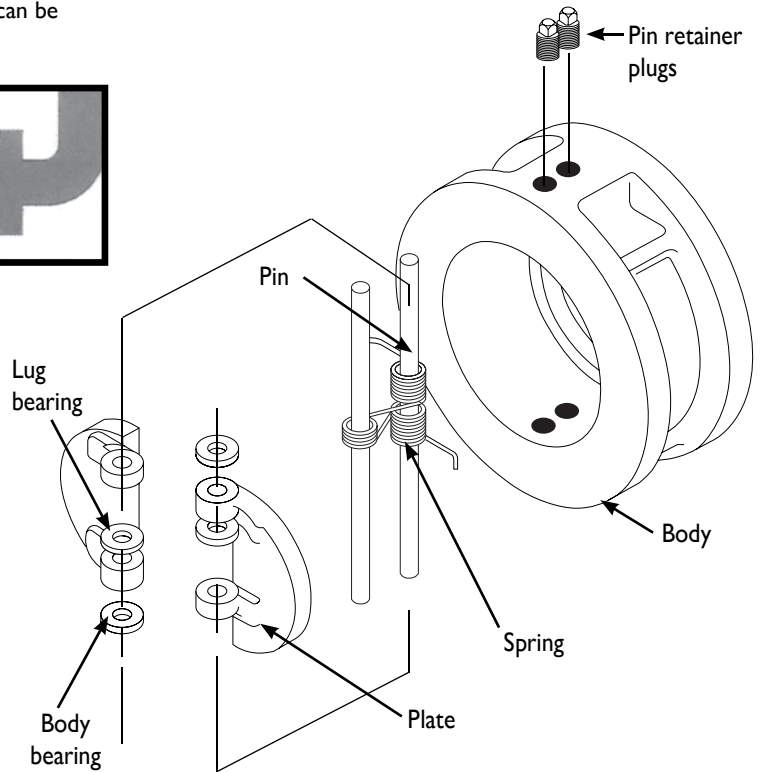

Operating Temperature Range for Seal Materials	
Material	Operating Temperature °C
EPDM	- 18 to 120
Buna-N	- 57 to 120
Neoprene	- 40 to 120
Metal*	- 267 to 537 (As Body)
Viton-A (FKM)	- 40 to 204
Viton-B	- 29 to 200

The temperature range is a general guide. As temperature increase the pressure rating of the valve decreases. Ask for pressure/temperature chart.
*Dependant on body material.

Spring Operating Temperature	
Spring Material	Maximum Temperature °C
Type 316SS	120~287
Inconel x 750 (Heat treated)	537

SHOCK BUMPERS

The problem Competitive designs do not have shock bumpers.

The solution The Supercheck design where required in larger sizes (& higher classes) uses shock bumpers on the back of each disc. These bumpers meet when the valve is in the full open position, thus preventing the discs from striking the stop pin. This arrangement reduces the shock force on the hinges; ensuring internal components have an extended cycle life with minimal wear under the most severe service conditions.



SLIM PLATE DESIGN

Standard in all sizes. Ensures lower cracking pressures & large flow rates.



WAFER CHECK DUAL FLAP STEEL BODY AGW SERIES - RETAINERLESS FUGITIVE EMISSION

CHARACTERISTICS

- High performance non slam
- Retainerless design meets fugitive emission requirements as there are no threaded plugs in the pressure boundary, thus eliminating potential leak paths. Slim plate design provides optimum flow & lower cracking pressures as well as longer life.
- Face to face to API 594, wall thickness & design to API 594, test & inspection to API 598, flanging to ANSI B16.5
- Vertical or Horizontal installation.
- Intrinsically Firesafe
- Very low head loss & minimum occupation of space.
- Suitable to fit between ANSI 150,300,600,900,1500 & 2500 flanges as well as API, BS, AS, JIS, EN, ISO etc
- Service Pressure
 - 150 class 20 Bar (285 PSI)
 - 300 class 51.1 Bar (740 PSI)
 - 600 class 102.1 Bar (1480 PSI)
 - 900 class 153.2 Bar (2220 PSI)
 - 1500 class 255.3 Bar (3705 PSI)
 - 2500 class 425.5 Bar (6170 PSI)
- Tight shut-off (resilient seat). Metal seat 50% lower leakage than API 598 allows.



API 6FA-5th
Firesafe Certified



DESIGN FEATURES

- **Alleviation from Water Hammer**
Reaction of torsion spring makes plates rapidly close prior to the start of reverse flow of fluid due to the cessation of power, thus preventing pump and other devices from causing damage due to Water Hammering.
- **Lower Head Loss**
Designed with optimum venturi to reduce head loss and is comparable with similar Duo-check Dual Plate type Check Valves.

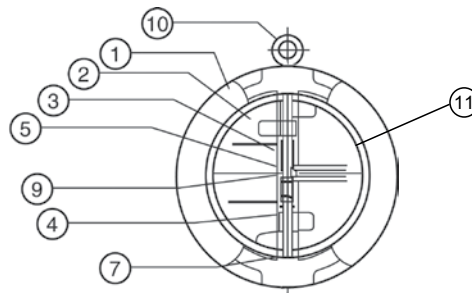

COMMON TRIM (WETTED PARTS) CONFIGURATIONS†

Body (1)	Plates (2)	Seat (11)	Spring (3)	Stop (5) & Hinge Pins (4)	Body plate & Spring Bearings (7/9)
WCB	WCB / CR13 / 304 / 316	Viton	316 or Inconel	316 SS / CR13	316 SS
WCB	WCB / CR13 / 304 / 316	Metal*	316 or Inconel	316 SS / CR13	316 SS
WCB	WCB / CR13 / 304 / 316	Viton	316 or Inconel	316 SS / CR13	316 SS
WCB	WCB / CR13 / 304 / 316	Buna-NBR	316 or Inconel	316 SS / CR13	316 SS
CF8 (304 SS)	304 SS	Buna-NBR	304 or Inconel	304 SS	316 SS
CF8 (304 SS)	304 SS	Metal*	316 or Inconel	316 SS	316 SS
CF8 (304 SS)	304 SS	Viton	316 or Inconel	316 SS	316 SS
CF8M (316 SS)	316 SS	Metal*	316 or Inconel	316 SS	316 SS
CF8M (316 SS)	316 SS	Viton	316 or Inconel	316 SS	316 SS

*Seat types - As per body, F6NM, HF, CR13, 316

† For other available trim configurations refer part number system.

AGW SERIES

INSTALLATION

In addition to the compact shape, SUPER-CHECK Valves can be installed either horizontally or vertically.



NON-SLAM

SUPERCHECK is a non-slam check valve because it operates on flow cessation, not flow reversal. The normal position of the plates is closed, held against the seat by the unique spring design. As flow begins, the heels of the two plates are lifted off the seat face on the central rib.

The cracking pressure is less than 21 kPa (3 psi) across most of the range (larger sizes and higher classes are proportionately higher). As flow increases, the plates then pivot against the spring pressure. Since the heels have already lifted off the rib seat there is no scrub or wear, either on the rib, body or plate seating surfaces. A pressure of only 28 kPa (4 psi) is required to keep the plates fully open in 150 class, proportionately higher in other classes and larger sizes. ("Light" springs also available)

When flow stops and pressure ceases the spring closes the plates. Flow reversal is then stopped by the closed Supercheck valve and any back pressure only serves to make the valve seal more tightly.

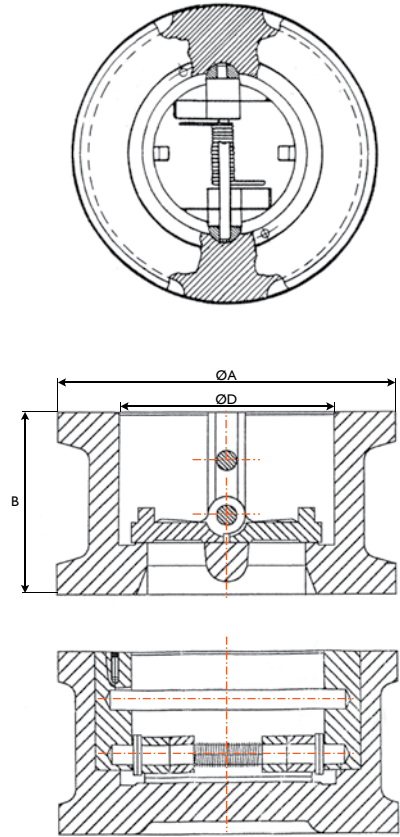

Operating Temperature Range for Seal Materials	
Material	Operating Temperature °C
EPDM	- 18 to 110
Buna-N	- 57 to 120
Neoprene	- 40 to 120
Metal*	- 267 to 537 (As Body)
Viton-A (FKM)	- 40 to 204
Viton-B	- 29 to 200

The temperature range is a general guide. As temperature increase the pressure rating of the valve decreases. Ask for pressure/temperature chart.
*Dependant on body material.

Spring Temperature	
Spring Material	Maximum Temperature °C
Type 316SS	120
Inconel x 750 (Heat treated)	537



SHOCK BUMPERS

The problem Competitive designs do not have shock bumpers.

The solution The Supercheck design where required in larger sizes (& higher classes) uses shock bumpers on the back of each disc. These bumpers meet when the valve is in the full open position, thus preventing the discs from striking the stop pin. This arrangement reduces the shock force on the hinges; ensuring internal components have an extended cycle life with minimal wear under the most severe service conditions.



Slim Plate Design
(all sizes)

Retainerless Body Design
Eliminates potential leak paths to the outside and a stronger casting.

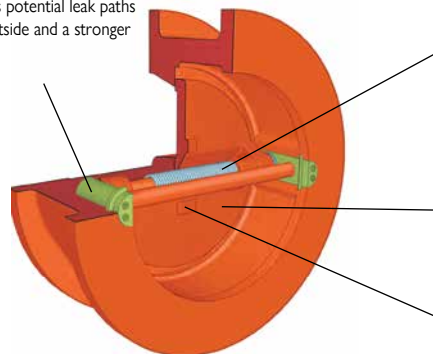

Independent Torsion Springs
on large sizes respond quickly to fluctuations in flow velocity

Inconel X750 Springs
are standard on all Carbon Steel and most Stainless Steel bodies.

Split Dual Disc Design
minimises pressure drop and shortens the distance each disc travels.

Shock Bumpers
stop discs and keeps them stable preventing unnecessary stress on the check valve

AGW SERIES

ANSI INSTALLATION DIMENSIONS

- 1-1/2" (40mm) Refer to drawings.
- Dimensions for larger valve sizes available upon request.
- Also available with EN, API, BS, AS and ISO dimensions.
- Approximate valve weight only.
- ***Threaded and Through-Bolt Lugged Body available

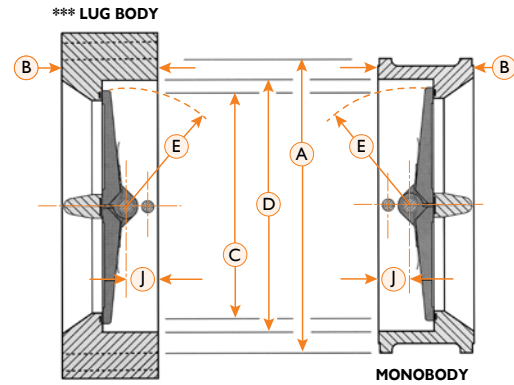

SIZE	SERIES	2" - 5" / 50mm-125mm - Valve Dimensions											
		A ^D		B		C*		D		E ^R		J	
		in	mm	in	mm	in	mm	in	mm	in	mm	in	mm
2"	125	4-1/8	105	2-1/8	54	1-1/2	38	2-3/8	60	1-5/32	29	15/16	24
	150	4-1/8	105	2-3/8	60	1-3/16	30	2-3/8	60	1-5/32	29	7/8	22
	250	4-3/8	111	2-1/8	54	1-1/2	38	2-3/8	60	1-5/32	29	15/16	24
	300	4-3/8	111	2-3/8	60	1-3/16	30	2-3/8	60	1-5/32	29	7/8	22
	400	4-3/8	111	2-3/8	60	1-3/16	30	2-3/8	60	1-5/32	29	7/8	22
	600	4-3/8	111	2-3/8	60	1-3/16	30	2-3/8	60	1-5/32	29	7/8	22
50 mm	900	5-5/8	143	2-3/4	70	0	0	2-3/8	60	1-5/32	29	1-3/16	30
	1500	5-5/8	143	2-3/4	70	0	0	2-3/8	60	1-5/32	29	1-3/16	30
	2500	5-3/4	146	2-3/4	70	0	0	2-3/8	60	1-5/32	29	1-3/16	30
2-1/2"	125	4-7/8	124	2-3/8	60	2-7/32	56	2-7/8	73	1-15/32	37	1	25
	150	4-7/8	124	2-5/8	67	2-1/8	54	2-7/8	73	1-15/32	37	1-1/8	29
	250	5-1/8	130	2-3/8	60	2-7/32	56	2-7/8	73	1-15/32	37	1	25
	300	5-1/8	130	2-5/8	67	2-1/8	54	2-7/8	73	1-15/32	37	1-1/8	29
	400	5-1/8	130	2-5/8	67	2-1/8	54	2-7/8	73	1-15/32	37	1-1/8	29
	600	5-1/8	130	2-5/8	67	2-1/8	54	2-7/8	73	1-15/32	37	1-1/8	29
65 mm	900	6-1/2	165	3-1/4	83	2	51	2-7/8	73	1-15/32	37	1-3/16	30
	1500	6-1/2	165	3-1/4	83	2	51	2-7/8	73	1-15/32	37	1-3/16	30
	2500	6-5/8	168	3-1/4	83	2	51	2-7/8	73	1-15/32	37	1-3/16	30
3"	125	5-3/8	137	2-5/8	67	2-25/32	71	3-5/8	92	1-3/4	44	1-1/16	27
	150	5-3/8	137	2-7/8	73	2-3/4	70	3-5/8	92	1-3/4	44	1-3/16	30
	250	5-7/8	149	2-5/8	67	2-25/32	71	3-5/8	92	1-3/4	44	1-1/16	27
	300	5-7/8	149	2-7/8	73	2-3/16	56	3-5/8	92	1-3/4	44	1-3/16	30
	400	5-7/8	149	2-7/8	73	2-3/16	56	3-5/8	92	1-3/4	44	1-3/16	30
	600	5-7/8	149	2-7/8	73	2-3/16	56	3-5/8	92	1-3/4	44	1-3/16	30
80 mm	900	6-5/8	168	3-1/4	83	2-1/8	54	3-5/8	92	1-3/4	44	1-7/16	37
	1500	6-7/8	175	3-1/4	83	2-1/8	54	3-5/8	92	1-3/4	44	1-7/16	37
	2500	7-3/4	197	3-3/8	86	2-1/8	54	3-5/8	92	1-3/4	44	1-7/16	37
4"	125	6-7/8	175	2-5/8	67	3-23/32	94	4-5/8	117	2-5/16	59	1-3/8	35
	150	6-7/8	175	2-7/8	73	3-11/16	94	4-5/8	117	2-5/16	59	1-7/16	37
	250	7-1/8	181	2-5/8	67	3-23/32	94	4-5/8	117	2-5/16	59	1-3/8	35
	300	7-1/8	181	2-7/8	73	3-11/16	94	4-5/8	117	2-5/16	59	1-7/16	37
	400	7	178	3-1/8	79	3-5/16	85	4-5/8	117	2-5/16	59	1-5/8	41
	600	7-5/8	194	3-1/8	79	3-5/16	85	4-5/8	117	2-5/16	59	1-5/8	41
100 mm	900	8-1/8	206	4	102	3-1/16	78	4-5/8	117	2-5/16	59	1-3/4	44
	1500	8-1/4	210	4	102	3-1/16	78	4-5/8	117	2-5/16	59	1-3/4	44
	2500	9-1/4	235	4-1/8	105	3-1/16	78	4-5/8	117	2-5/16	59	1-3/4	44
5"	125	7-3/4	197	3-1/4	83	4-5/8	117	5-5/8	143	2-11/16	68	1-3/8	35
	150	7-3/4	197	3-1/4	83	4-5/8	117	5-5/8	143	2-11/16	68	1-3/8	35
	250	8-1/2	216	3-1/4	83	4-5/8	117	5-5/8	143	2-11/16	68	1-3/8	35
	300	8-1/2	216	3-1/4	83	4-5/8	117	5-5/8	143	2-11/16	68	1-3/8	35
	400	8-3/8	213	4-1/8	105	4-1/2	114	5-5/8	143	2-11/16	68	1-3/4	44
	600	9-1/2	241	4-1/8	105	4-1/2	114	5-5/8	143	2-11/16	68	1-3/4	44

* Minimum Flange Bore

AGW SERIES

ANSI INSTALLATION DIMENSIONS (Continued)

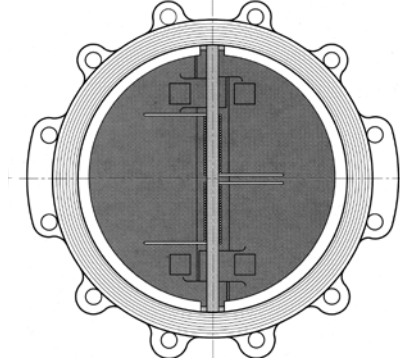
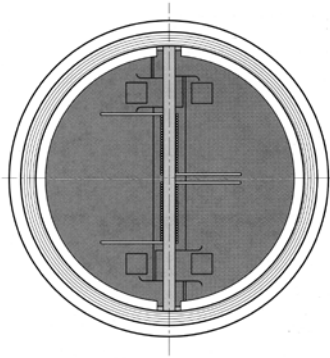

SIZE	SERIES	MONO BODY							LUGGED BODY ***						
		WEIGHT		STUD L. **		STUD DIA.		# REQ'D	WEIGHT		BOLT L. **		BOLT DIA.		# REQ'D
		lbs	kg	in	mm	in	mm		lbs	kg	in	mm	in	mm	
2"	125	5	2.10	5-1/2	140	5/8	16	4	16	6.90	1-3/4	44	5/8	16	8
	150	6	3.00	5-3/4	146	5/8	16	4	18	8.20	1-3/4	44	5/8	16	8
	250	6	2.40	5-3/4	146	5/8	16	8	18	8.20	2	51	5/8	16	16
	300	7	3.20	6	152	5/8	16	8	18	8.20	2	51	5/8	16	16
	400	7	3.20	6-3/4	171	5/8	16	8	18	8.20	2-1/4	57	5/8	16	16
	600	7	3.20	6-3/4	171	5/8	16	8	18	8.20	2-1/4	57	5/8	16	16
50 mm	900	14	6.00	8-3/4	222	7/8	22	8	26	16.00	3	76	7/8	22	16
	1500	14	6.00	8-3/4	222	7/8	22	8	27	16.00	3	76	7/8	22	16
	2500	15	7.00	10	254	1	25	8	29	19.00	3-3/4	95	1	25	16
2-1/2"	125	9	3.00	6	152	5/8	16	4	14	6.40	2	51	5/8	16	8
	150	10	5.00	6-1/4	159	5/8	16	4	27	12.00	2	51	5/8	16	8
	250	10	5.00	6-1/2	165	3/4	19	8	26	12.00	2-1/4	57	3/4	19	16
	300	11	5.00	6-3/4	171	3/4	19	8	27	12.00	2-1/4	57	3/4	19	16
	400	11	5.00	7-1/2	191	3/4	19	8	27	12.00	2-1/2	64	3/4	19	16
	600	11	5.00	7-1/2	191	3/4	19	8	27	12.00	2-1/2	64	3/4	19	16
65 mm	900	21	7.00	9-3/4	248	1	25	8	40	18.00	3-1/4	83	1	25	16
	1500	22	10.00	9-3/4	248	1	25	8	42	19.00	3-1/4	83	1	25	16
	2500	28	10.00	11-1/4	286	1-1/8	29	8	53	24.00	4	102	1-1/8	29	16
3"	125	9	3.30	6-1/2	165	5/8	16	4	15	6.80	2	51	5/8	16	8
	150	10	6.00	6-3/4	171	5/8	16	4	15	6.80	2	51	5/8	16	8
	250	10	5.00	7	178	3/4	19	8	26	12.00	2-1/2	64	3/4	19	16
	300	12	7.00	7-1/4	184	3/4	19	8	27	12.00	2-1/2	64	3/4	19	16
	400	12	7.00	8	203	3/4	19	8	27	12.00	2-3/4	70	3/4	19	16
	600	12	7.00	8	203	3/4	19	8	27	12.00	2-3/4	70	3/4	19	16
80 mm	900	23	11.00	9-1/4	235	7/8	22	8	44	20.00	3	76	7/8	22	16
	1500	24	11.00	10-1/2	267	1-1/8	29	8	50	23.00	3-3/4	95	1-1/8	29	16
	2500	29	14.00	12-1/4	311	1-1/4	32	8	55	25.00	4-1/2	114	1-1/4	32	16
4"	125	11	5.40	6-1/2	165	5/8	16	8	29	13.00	2	51	5/8	16	16
	150	15	8.00	6-3/4	171	5/8	16	8	29	13.00	2	51	5/8	16	16
	250	15	6.80	7-1/4	184	3/4	19	8	36	16.00	2-1/2	64	3/4	19	16
	300	16	8.00	7-1/2	191	3/4	19	8	38	17.00	2-1/2	64	3/4	19	16
	400	16	12.00	8-3/4	222	7/8	22	8	47	21.00	3	76	7/8	22	16
	600	17	12.00	9	229	7/8	22	8	51	23.00	3	76	7/8	22	16
100 mm	900	36	18.00	11	279	1-1/8	29	8	68	31.00	3-1/2	89	1-1/8	29	16
	1500	37	20.00	12	305	1-1/4	32	8	78	35.00	4	102	1-1/4	32	16
	2500	50	25.00	14-1/4	362	1-1/2	38	8	95	43.00	5-1/4	133	1-1/2	38	16
5"	125	23	7.00	7-1/4	184	3/4	19	8	36	16.00	2-1/4	57	3/4	19	16
	150	19	12.00	7-1/4	184	3/4	19	8	41	19.00	2-1/4	57	3/4	19	16
	250	23	13.00	8-1/4	210	3/4	19	8	44	20.00	2-3/4	70	3/4	19	16
	300	20	14.00	8-1/4	210	3/4	19	8	46	21.00	2-3/4	70	3/4	19	16
	400	40	14.00	10	254	7/8	22	8	83	38.00	3	76	7/8	22	16
	600	49	22.00	10-3/4	273	1	25	8	97	44.00	3-1/2	89	1	25	16

** Stud and Bolt length is for Wafer Check with Raised Face End Connection. For Ring Joint End Connection contact us.

*** Threaded and Through-Bolt Lug Body available.

AGW SERIES

ANSI INSTALLATION DIMENSIONS

- 1-1/2" (40mm) Refer to drawings.
- Dimensions for larger valve sizes available upon request.
- Also available with EN, API, BS, AS and ISO dimensions.
- Approximate valve weight only.
- ***Threaded and Through-Bolt Lugged Body available

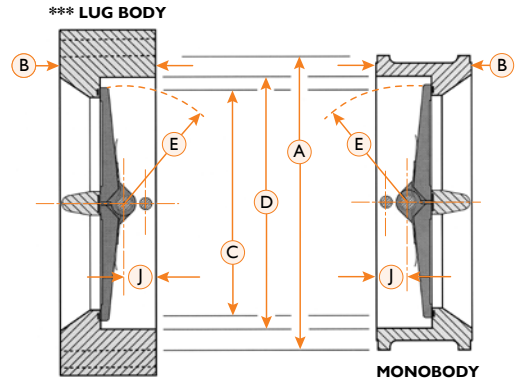

SIZE	6" - 16" / 150mm-400mm - VALVE DIMENSIONS												
	SERIES	A ^D		B		C*		D		E ^R		J	
		in	mm	in	mm	in	mm	in	mm	in	mm	in	mm
6"	125	8-3/4	222	3-3/4	95	5-9/16	141	6-5/8	168	3-9/32	83	1-11/16	43
	150	8-3/4	222	3-7/8	98	5-9/16	141	6-5/8	168	3-9/32	83	1-11/16	43
	250	9-7/8	251	3-3/4	95	5-9/16	141	6-5/8	168	3-9/32	83	1-11/16	43
	300	9-7/8	251	3-7/8	98	5-9/16	141	6-5/8	168	3-9/32	83	1-11/16	43
	400	9-3/4	248	5-3/8	137	4-3/4	121	6-5/8	168	3-9/32	83	2-5/16	59
150 mm	600	10-1/2	267	5-3/8	137	4-3/4	121	6-5/8	168	3-9/32	83	2-5/16	59
	900	11-3/8	289	6-1/4	159	3-5/8	92	6-5/8	168	3-9/32	83	2-13/16	71
	1500	11-1/8	283	6-1/4	159	3-5/8	92	6-5/8	168	3-9/32	83	2-13/16	71
8"	2500	12-1/2	318	6-1/4	159	3-5/8	92	6-5/8	168	3-9/32	83	2-13/16	71
	125	11	279	5	127	7-1/2	191	8-5/8	219	4-1/4	108	2-3/16	56
	150	11	279	5	127	7-1/2	191	8-5/8	219	4-1/4	108	2-3/16	56
	250	12-1/8	308	5	127	7-1/2	191	8-5/8	219	4-1/4	108	2-3/16	56
	300	12-1/8	308	5	127	7-1/2	191	8-5/8	219	4-1/4	108	2-3/16	56
	400	12	305	6-1/2	165	7-1/2	191	8-5/8	219	4-1/4	108	2-1/2	64
	600	12-5/8	321	6-1/2	165	6-25/32	172	8-5/8	219	4-1/4	108	2-9/16	65
200 mm	900	14-1/8	359	8-1/8	206	6-1/2	165	8-5/8	219	4-1/4	108	2-7/8	73
	1500	13-7/8	352	8-1/8	206	6-1/2	165	8-5/8	219	4-1/4	108	2-7/8	73
	2500	15-1/4	387	8-1/8	206	6-1/16	155	8-5/8	219	4-1/4	108	3	76
	125	13-3/8	340	5-1/2	140	9-7/16	240	10-3/4	273	5-7/32	133	2-5/16	59
	150	13-3/8	340	5-3/4	146	9-7/16	240	10-3/4	273	5-7/32	133	2-5/16	59
10"	250	14-1/4	362	5-1/2	140	9-7/16	240	10-3/4	273	5-7/32	133	2-5/16	59
	300	14-1/4	362	5-3/4	146	9-7/16	240	10-3/4	273	5-7/32	133	2-5/16	59
	400	14-1/8	359	8-3/8	213	8-1/2	216	10-3/4	273	5-7/32	133	3-3/16	81
	600	15-3/4	400	8-3/8	213	8-1/2	216	10-3/4	273	5-7/32	133	3-3/16	81
	900	17-1/8	435	9-1/2	241	8-3/16	208	10-3/4	273	5-7/32	133	3-3/8	86
	1500	17-1/8	435	9-3/4	248	8	203	10-3/4	273	5-7/32	133	3-1/2	89
	2500	18-3/4	476	10	254	6-1/2	165	10-3/4	273	5-7/32	133	4-3/16	106
12"	125	16-1/8	410	7-1/8	181	11-1/4	286	12-7/8	327	6-3/8	162	3-1/4	83
	150	16-1/8	410	7-1/8	181	11-1/4	286	12-7/8	327	6-3/8	162	3-1/4	83
	250	16-5/8	422	7-1/8	181	11-1/4	286	12-7/8	327	6-3/8	162	3-1/4	83
	300	16-5/8	422	7-1/8	181	11-1/4	286	12-7/8	327	6-3/8	162	3-1/4	83
	400	16-1/2	419	9	229	10-9/16	268	12-7/8	327	6-3/8	162	3-5/8	92
	600	18	457	9	229	10-9/16	268	12-7/8	327	6-3/8	162	3-5/8	92
	900	19-5/8	498	11-1/2	292	9-3/4	248	12-7/8	327	6-3/8	162	4-1/4	108
	1500	20-1/2	521	12	305	9-1/4	235	12-7/8	327	6-3/8	162	4-1/2	114
	2500	21-5/8	549	12	305	9-1/4	235	12-7/8	327	6-3/8	162	4-1/2	114
	14"	125	17-3/4	451	7-1/4	184	12-5/8	321	14	356	6-7/8	175	3
150		17-3/4	451	7-1/4	184	12-5/8	321	14	356	6-7/8	175	3	76
250		19-1/8	486	8-3/4	222	12-7/16	316	14	356	6-7/8	175	3-3/16	81
300		19-1/8	486	8-3/4	222	12-7/16	316	14	356	6-7/8	175	3-3/16	81
400		19	483	10-3/4	273	11-15/16	303	14	356	6-15/16	176	3-5/8	92
600		19-3/8	492	10-3/4	273	11-15/16	303	14	356	6-15/16	176	3-3/8	86
900		20-1/2	521	14	356	8-15/16	227	14	356	6-15/16	177	5-1/2	140
350 mm	1500	22-3/4	578	14	356	8-15/16	227	14	356	6-15/16	177	5-1/2	140
	125	20-1/4	514	7-1/2	191	14-11/16	373	16	406	7-23/32	196	2-1/2	64
	150	20-1/4	514	7-1/2	191	14-11/16	373	16	406	7-23/32	196	2-1/2	64
	250	21-1/4	540	9-1/8	232	14-1/2	368	16	406	7-23/32	196	3	76
	300	21-1/4	540	9-1/8	232	14-1/2	368	16	406	7-23/32	196	3	76
400 mm	400	21-1/8	537	12	305	13-1/2	343	16	406	7-25/32	198	4-1/4	108
	600	22-1/4	565	12	305	13-1/2	343	16	406	7-25/32	198	4-1/4	108
	900	22-5/8	575	15-1/8	384	11-7/32	286	16	406	7-13/16	199	5-5/8	143
	1500	25-1/4	641	15-1/8	384	11-7/32	286	16	406	7-13/16	199	5-5/8	143

* Minimum Flange Bore

AGW SERIES
ANSI INSTALLATION DIMENSIONS (Continued)

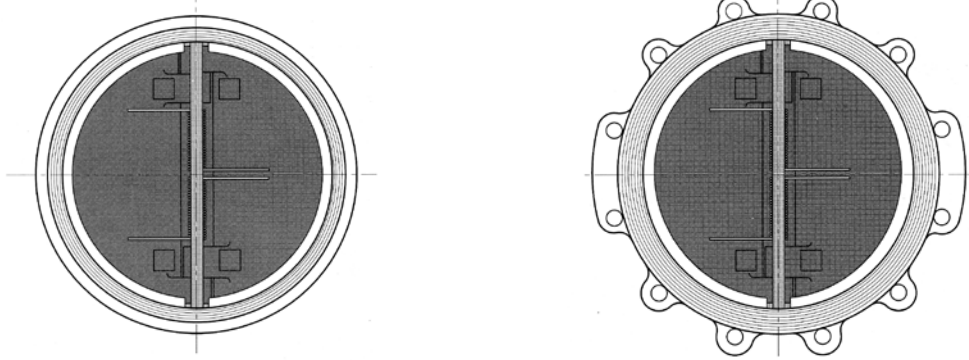

SIZE	SERIES	MONO BODY							LUGGED BODY ***						
		WEIGHT		STUD L. **		STUD DIA.		# REQ'D	WEIGHT		BOLT L. **		BOLT DIA.		# REQ'D
		lbs	kg	in	mm	in	mm		lbs	kg	in	mm	in	mm	
6"	125	28	10.00	8	203	3/4	19	8	41	27.00	2-1/4	57	3/4	19	16
	150	30	16.00	8	203	3/4	19	8	51	32.00	2-1/4	57	3/4	19	16
	250	35	16.00	8-3/4	222	3/4	19	12	78	36.00	2-3/4	70	3/4	19	24
	300	36	20.00	9	229	3/4	19	12	81	38.00	2-3/4	70	3/4	19	24
	400	64	36.00	11-1/2	292	7/8	22	12	140	75.00	3-1/4	83	7/8	22	24
	600	65	36.00	12-1/4	311	1	25	12	151	81.00	3-1/2	89	1	25	24
	900	115	52.00	14	356	1-1/8	29	12	240	114.00	4	102	1-1/8	29	24
150 mm	1500	121	52.00	16-3/4	425	1-3/8	35	12	242	119.00	5-1/4	133	1-3/8	35	24
	2500	132	70.00	20	508	2	51	8	251	175.00	7	178	2	51	16
8"	125	49	20.00	9-1/2	241	3/4	19	8	88	56.00	2-1/2	64	3/4	19	16
	150	50	32.00	9-1/2	241	3/4	19	8	91	63.00	2-1/2	64	3/4	19	16
	250	67	34.00	10-3/4	273	7/8	22	12	141	69.00	3	76	7/8	22	24
	300	69	37.00	10-3/4	273	7/8	25	12	151	74.00	3-1/4	83	1	25	24
	400	105	61.00	13-1/2	343	1	29	12	237	129.00	3-3/4	95	1-1/8	29	24
	600	115	61.00	14-1/4	362	1-1/8	29	12	261	134.00	4	102	1-1/8	29	24
	900	252	115.00	17	432	1-3/8	35	12	443	201.00	4-1/2	114	1-3/8	35	24
200 mm	1500	205	103.00	19-3/4	502	1-5/8	41	12	401	221.00	6	152	1-5/8	41	24
	2500	257	130.00	23-1/2	597	2	51	12	461	309.00	7-3/4	197	2	51	24
10"	125	83	31.00	10-1/4	260	7/8	22	12	136	78.00	2-1/2	64	7/8	22	24
	150	92	48.00	10-1/2	267	7/8	22	12	151	93.00	2-1/2	64	7/8	22	24
	250	107	51.00	12	305	1	25	16	236	107.00	3-1/2	89	1	25	32
	300	93	56.00	12-1/4	311	1	25	16	251	114.00	3-1/2	89	1	25	32
	400	210	108.00	16	406	1-1/8	29	16	431	196.00	4	102	1-1/8	29	32
	600	209	108.00	17	432	1-1/4	32	16	460	234.00	4-1/2	114	1-1/4	32	32
	900	348	176.00	19	483	1-3/8	35	16	661	330.00	4-3/4	121	1-3/8	35	32
250 mm	1500	378	180.00	23-1/4	591	1-7/8	48	12	711	361.00	6-3/4	171	1-7/8	48	24
	2500	466	220.00	29-1/2	749	2-1/2	64	12	751	489.00	9-3/4	248	2-1/2	64	24
12"	125	149	56.00	12	305	7/8	22	12	248	140.00	2-3/4	70	7/8	22	24
	150	156	78.00	12	305	7/8	22	12	241	170.00	2-3/4	70	7/8	22	24
	250	166	79.00	14	356	1-1/8	29	16	330	200.00	3-3/4	95	1-1/8	29	32
	300	139	91.00	14	356	1-1/8	29	16	342	240.00	3-3/4	95	1-1/8	29	32
	400	255	116.00	17-1/4	438	1-1/4	32	16	451	250.00	4-1/4	108	1-1/4	32	32
	600	264	151.00	18	457	1-1/4	32	20	587	304.00	4-1/2	114	1-1/4	32	40
	900	490	245.00	21-3/4	552	1-3/8	35	20	981	509.00	5-1/4	133	1-3/8	35	40
300 mm	1500	540	330.00	27	686	2	51	16	972	637.00	7-1/2	191	2	51	32
	2500	678	400.00	33-1/2	851	2-3/4	70	12	1118	747.00	10-3/4	273	2-3/4	70	24
14"	125	183	83.00	12-3/4	324	1	25	12	271	150.00	3	76	1	25	24
	150	210	95.00	12-3/4	324	1	25	12	291	199.00	3	76	1	25	24
	250	285	136.00	16	406	1-1/8	29	20	504	229.00	3-3/4	95	1-1/8	29	40
	300	270	146.00	16	406	1-1/8	29	20	543	246.00	3-3/4	95	1-1/8	29	40
	400	440	195.00	19-1/4	489	1-1/4	32	20	792	461.00	4-1/4	108	1-1/4	32	40
	600	430	195.00	20-1/4	514	1-3/8	35	20	817	571.00	4-3/4	121	1-3/8	35	40
	900	926	420.00	25	635	1-1/2	38	20	1241	775.00	5-1/2	140	1-1/2	38	40
350 mm	1500	948	440.00	30-1/4	768	2-1/4	57	16	1659	928.00	8-1/4	210	2-1/4	57	32
	125	213	116.00	13	330	1	25	16	441	211.00	3	76	1	25	32
16"	150	214	125.00	13	330	1	25	16	464	246.00	3	76	1	25	32
	250	375	172.00	16-3/4	425	1-1/4	32	20	761	398.00	4-1/4	108	1-1/4	32	40
	300	356	188.00	16-3/4	425	1-1/4	32	20	792	489.00	4-1/4	108	1-1/4	32	40
	400	510	292.00	21	533	1-3/8	35	20	1046	501.00	4-1/2	114	1-3/8	35	40
	600	504	292.00	22-1/4	565	1-1/2	38	20	1058	548.00	5-1/4	133	1-1/2	38	40
	900	1152	524.00	26-1/2	673	1-5/8	41	20	2074	943.00	5-3/4	146	1-5/8	41	40
	1500	1380	627.00	32-3/4	832	2-1/2	64	16	2277	1035.00	9	229	2-1/2	64	32

** Stud and Bolt length is for Wafer Check with Raised Face End Connection. For Ring Joint End Connection contact us.
*** Threaded and Through-Bolt Lug Body available.

AGW SERIES

ANSI INSTALLATION DIMENSIONS

- 1-1/2" (40mm) Refer to drawings.
- Dimensions for larger valve sizes available upon request.
- Also available with EN, API, BS, AS and ISO dimensions.
- Approximate valve weight only.
- ***Threaded and Through-Bolt Lugged Body available
- A^D Dimensions for 30" and larger steel valves per ASME B16.47 & MSS-SP-44.

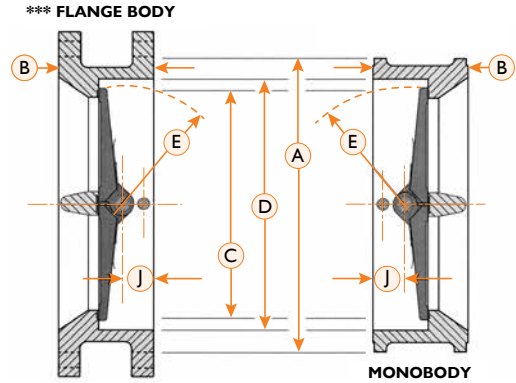

SIZE	SERIES	18" - 48" / 450mm-1200mm - VALVE DIMENSIONS											
		A ^D		B		C*		D		E ^R		J	
		in	mm	in	mm	in	mm	in	mm	in	mm	in	mm
18"	125	21-5/8	549	8	203	16-9/16	421	18-5/16	465	8-7/8	225	3-1/2	89
	150	21-5/8	549	8	203	16-9/16	421	18-5/16	465	8-7/8	225	3-1/2	89
	250	23-1/2	597	10-3/8	264	16-3/8	416	18-5/16	465	8-7/8	225	3-3/4	95
	300	23-1/2	597	10-3/8	264	16-3/8	416	18-5/16	465	8-7/8	225	3-3/4	95
	400	23-3/8	594	14-1/4	362	13-3/4	349	18-5/16	465	8-15/16	227	5-7/8	149
450 mm	600	24-1/8	613	14-1/4	362	13-3/4	349	18-5/16	465	8-15/16	227	5-7/8	149
	900	25-1/8	638	17-3/4	451	13-15/16	354	18-5/16	465	8-15/16	227	5-7/8	149
	1500	27-3/4	705	18-7/16	468	10-15/16	278	18-5/16	465	8-15/16	227	7-1/4	184
20"	125	23-7/8	606	8-3/8	213	18-9/16	471	20	508	9-3/4	248	3-3/8	86
	150	23-7/8	606	8-5/8	219	18-7/16	468	20	508	9-3/4	248	3-1/2	89
	250	25-3/4	654	11-1/2	292	18-9/16	471	20	508	9-3/4	248	3-7/8	98
	300	25-3/4	654	11-1/2	292	18-1/16	459	20	508	9-3/4	248	3-7/8	98
	400	25-1/2	648	14-1/2	368	16-15/16	430	20	508	9-27/32	250	5-1/4	133
500 mm	600	26-7/8	683	14-1/2	368	16-15/16	430	20	508	9-27/32	250	5-1/4	133
	900	27-1/2	699	17-3/4	451	17-1/16	434	20	508	10	254	5-1/2	140
	125	28-1/4	718	8-3/4	222	21-5/8	549	24	610	11-5/16	287	3-3/4	95
24"	150	28-1/4	718	8-3/4	222	21-5/8	549	24	610	11-5/16	287	3-3/4	95
	250	30-1/2	775	12-1/2	318	20-11/16	525	24	610	11-5/16	287	4-7/8	124
	300	30-1/2	775	12-1/2	318	20-11/16	525	24	610	11-5/16	287	4-7/8	124
	400	30-1/4	768	15-1/2	394	20-5/16	516	24	610	11-13/32	290	5-1/4	133
	600	31-1/8	791	17-1/4	438	20-1/2	521	24	610	11-13/32	290	6	152
600 mm	900	33	838	19-1/2	495	20-15/32	520	24	610	11-7/16	291	6	152
	125	34-3/4	883	12	305	28-7/16	722	30-3/8	772	14-3/4	375	3-15/16	100
	150	34-3/4	883	12	305	28-7/16	722	30-3/8	772	14-3/4	375	3-15/16	100
750 mm	250	37-1/2	953	14-1/2	368	27-5/8	702	30-3/8	772	14-3/4	375	5-1/2	140
	300	37-1/2	953	14-1/2	368	27-5/8	702	30-3/8	772	14-3/4	375	5-1/2	140
	400	37-1/8	943	18-1/8	460	26-5/8	676	30-3/8	772	14-7/8	378	6-7/8	175
	600	38-1/4	972	19-7/8	505	26-1/2	673	30-3/8	772	14-7/8	378	7	178
	125	41-1/4	1048	14-1/2	368	34-3/8	873	36	914	17-13/16	452	4-3/4	121
36"	150	41-1/4	1048	14-1/2	368	34-3/8	873	36	914	17-13/16	452	4-3/4	121
	250	44	1118	19	483	33-1/2	851	36	914	17-13/16	452	6-1/8	156
	300	44	1118	19	483	33-1/2	851	36	914	17-13/16	452	6-1/8	156
	400	44	1118	25	635	30-3/8	772	36	914	17-7/8	456	9-13/16	249
	600	44-1/2	1130	25	635	30-3/8	772	36	914	17-7/8	456	9-13/16	249
42"	125	48	1219	17	432	40-9/16	1030	42	1067	20-27/32	529	5-1/4	133
	150	48	1219	17	432	40-9/16	1030	42	1067	20-27/32	529	5-1/4	133
	250	50-3/4	1289	22-3/8	568	39-1/2	1003	42	1067	20-27/32	529	7	178
	300	45-7/8	1165	22-3/8	568	39-1/2	1003	42	1067	20-27/32	529	7	178
	400	46-3/8	1178	27-5/8	702	37-7/16	951	42	1067	20-7/8	531	9-5/8	244
1100 mm	600	48	1219	27-5/8	702	37-7/16	951	42	1067	20-7/8	531	9-5/8	244
	125	54-1/2	1384	20-5/8	524	44-3/16	1122	48	1219	23-19/32	599	8-5/8	219
	150	54-1/2	1384	20-5/8	524	44-3/16	1122	48	1219	23-19/32	599	8-5/8	219
48"	250	58-3/4	1492	24-3/4	629	42-1/4	1073	48	1219	23-19/32	599	10-3/4	273
	300	52-1/8	1324	24-3/4	629	42-1/4	1073	48	1219	23-19/32	599	10-3/4	273

* Minimum Flange Bore
 *** Lugged body also available.

AGW SERIES

ANSI INSTALLATION DIMENSIONS (Continued)

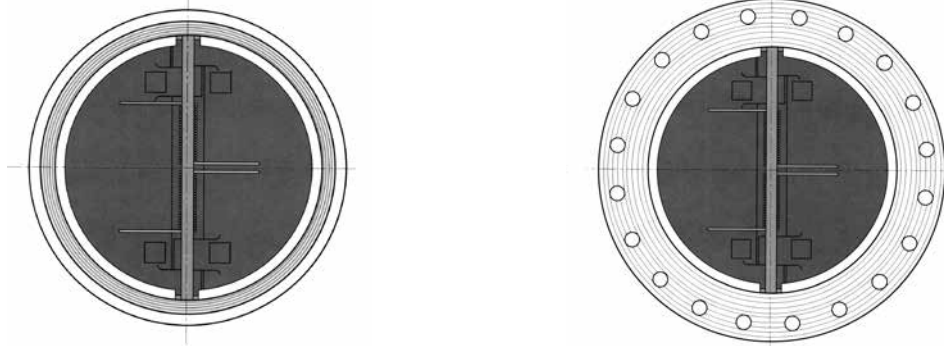

SIZE	SERIES	MONO BODY							FLANGED BODY ***						
		WEIGHT		STUD L. **		STUD DIA.		# REQ'D	WEIGHT		BOLT L. **		BOLT DIA.		# REQ'D
		lbs	kg	in	mm	in	mm		lbs	kg	in	mm	in	mm	
18"	125	305	143.00	14	356	1-1/8	29	16	419	190.00	3-1/4	83	1-1/8	29	32
	150	308	143.00	14	356	1-1/8	29	16	431	196.00	3-1/4	83	1-1/8	29	32
	250	470	231.00	18-1/4	464	1-1/4	32	24	623	283.00	4	102	1-1/4	32	48
	300	500	294.00	18-1/4	464	1-1/4	32	24	651	295.00	4	102	1-1/4	32	48
	400	710	322.00	23-1/2	597	1-3/8	35	24	981	445.00	4-1/2	114	1-3/8	35	48
450 mm	600	740	394.00	25-1/4	641	1-5/8	41	20	1011	459.00	5-1/2	140	1-5/8	41	40
	900	1039	598.00	30-3/4	781	1-7/8	48	20	1418	643.00	6-1/2	165	1-7/8	48	40
	1500	1621	791.00	38-1/4	972	2-3/4	70	16	2551	1157.00	9-3/4	248	2-3/4	70	32
20"	125	338	172.00	14-3/4	375	1-1/8	29	20	488	221.00	3-1/4	83	1-1/8	29	40
	150	357	197.00	15	381	1-1/8	29	20	501	227.00	3-1/4	83	1-1/8	29	40
	250	590	268.00	19-3/4	502	1-1/4	32	24	757	343.00	4-1/4	108	1-1/4	32	48
	300	590	329.00	19-3/4	502	1-1/4	32	24	780	354.00	4-1/4	108	1-1/4	32	48
	400	841	445.00	24-1/4	616	1-1/2	38	24	1191	540.00	4-3/4	121	1-1/2	38	48
500 mm	600	980	508.00	26	660	1-5/8	41	24	1279	580.00	5-3/4	146	1-5/8	41	48
	900	1421	637.00	31-3/4	806	2	51	20	1892	858.00	6-3/4	171	2	51	40
	125	522	261.00	15-3/4	400	1-1/4	32	20	657	298.00	3-1/2	89	1-1/4	32	40
24"	150	500	290.00	15-3/4	400	1-1/4	32	20	682	309.00	3-1/2	89	1-1/4	32	40
	250	690	458.00	21-3/4	552	1-1/2	38	24	981	445.00	4-3/4	121	1-1/2	38	48
	300	727	499.00	21-3/4	552	1-1/2	38	24	1011	459.00	4-3/4	121	1-1/2	38	48
	400	1200	544.00	26-1/4	667	1-3/4	44	24	1551	704.00	5-1/4	133	1-3/4	44	48
	600	1445	819.00	30-1/2	775	1-7/8	48	24	1851	840.00	6-1/2	165	1-7/8	48	48
600 mm	900	1900	1230.00	37	940	2-1/2	64	20	2786	1264.00	8-1/2	216	2-1/2	64	40
	125	1135	486.00	21-1/4	540	1-1/4	32	28	1273	577.00	4-3/4	121	1-1/4	32	56
	150	1100	558.00	21-1/4	540	1-1/4	32	28	1321	599.00	4-3/4	121	1-1/4	32	56
30"	250	1400	853.00	26-1/2	673	1-3/4	44	28	1883	854.00	5-3/4	146	1-3/4	44	56
	300	1500	930.00	26-1/2	673	1-3/4	44	28	1974	895.00	5-3/4	146	1-3/4	44	56
	400	2500	1135.00	31-1/2	800	2	51	28	2773	1258.00	6-1/2	165	2	51	56
	600	2640	1531.00	34-1/4	870	2	51	28	2987	1355.00	7	178	2	51	56
	125	1457	890.00	25-1/2	648	1-1/2	38	32	1811	821.00	5-1/2	140	1-1/2	38	64
36"	150	1520	690.00	25-1/2	648	1-1/2	38	32	1898	861.00	5-1/2	140	1-1/2	38	64
	250	3050	1608.00	32-1/4	819	2	51	32	3811	1729.00	6-1/2	165	2	51	64
	300	3200	1452.00	32-1/4	819	2	51	32	3926	1781.00	6-1/2	165	2	51	64
	400	4070	1846.00	39-1/4	997	2	51	32	5241	2377.00	7	178	2	51	64
	600	4200	2220.00	41	1041	2-1/2	64	28	5364	2433.00	8	203	2-1/2	64	56
42"	125	2700	1270.00	28-3/4	730	1-1/2	38	36	3179	1442.00	6	152	1-1/2	38	72
	150	2800	1270.00	28-3/4	730	1-1/2	38	36	3236	1468.00	6	152	1-1/2	38	72
	250	3830	2622.00	37	940	2	51	36	4651	2110.00	7-1/4	184	2	51	72
	300	4000	2147.00	37	940	2	51	36	4830	2191.00	7-1/4	184	2	51	72
	400	5650	2563.00	43-1/4	1099	1-7/8	48	32	6921	3139.00	7-3/4	197	1-7/8	48	64
1100 mm	600	5800	3300.00	47	1194	2-1/2	64	28	7048	3197.00	9-3/4	248	2-1/2	64	56
	125	3900	1769.00	33-1/4	845	1-1/2	38	44	4711	2137.00	6-1/4	159	1-1/2	38	88
	150	4400	1996.00	33-1/4	845	1-1/2	38	44	4899	2219.00	6-1/4	159	1-1/2	38	88
48"	250	5500	2981.00	40-1/2	1029	2	51	40	6477	2938.00	7-3/4	197	2	51	80
	300	5700	2981.00	40-1/2	1029	2	51	40	6653	3018.00	7-3/4	197	2	51	80

** Stud and Bolt length is for Raised Face End Connection. For Ring Joint End Connection contact us.

*** Lugged body also available.

ASG/AGW SERIES PART NUMBER SYSTEM

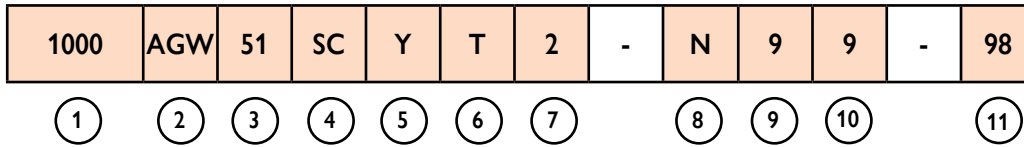

① Size	
MM	Valve Size.

② Style	
ASG	Standard Design.
AGW	Retainerless Design

③ End Connection	
12	ANSI Class 125
15	ANSI Class 150
25	ANSI Class 250
30	ANSI Class 300
40	ANSI Class 400
60	ANSI Class 600
90	ANSI Class 900
150	ANSI Class 1500
250	ANSI Class 2500
269	ANSI Class 2690
450	ANSI Class 4500
21	API 2000
31	API 3000
51	API 5000
101	API 10000
151	API 15000
AS14	AS4087* PN14
AS16	AS4087* PN16
AS21	AS4087 PN21
AS35	AS4087 PN35
BD12	AS/2129* Table D
BE12	AS/2129* Table E
ABF	AS/2129* Table F
ABH	AS/2129* Table H
PN6	ISO 7005/BS/EN/AS 4331 PN06
PN10	ISO 7005/BS/EN/AS 4331 PN10
PN16	ISO 7005/BS/EN/AS 4331 PN16
PN25	ISO 7005/BS/EN/AS 4331 PN25
PN40	ISO 7005/BS/EN/AS 4331 PN40
PN50	ISO 7005/BS/EN/AS 4331 PN50
PN110	ISO 7005/BS/EN/AS 4331 PN110
PN150	ISO 7005/BS/EN/AS 4331 PN150
PN260	ISO 7005/BS/EN/AS 4331 PN260
PN420	ISO 7005/BS/EN/AS 4331 PN420

* AS 4087 PN14/16 and AS 2129 Table D dual conforming.

④ Body and Plates*	
A	4130/4140/A487 4C (API 6A)
C	316/CF8M Stainless Steel
D	304/CF8 Stainless Steel
F	Alloy 20
G	Low Temp. C.S. LF2/LCB
H	Cast Iron
HD	Ductile Iron
N	Monel
S	Carbon Steel A105/WCB
T	CG8M/317 SS
U	WC6/F11 Alloy Steel
V	CF8C/347 SS
W	CF3M/316L SS
X	WC9/F22 Alloy Steel
Y	C5/F5 Alloy Steel
AC	Aluminium Bronze
AF	F6A/410/CA15 Stainless Steel
BZ	Bronze
CA	CD3MN/4A/F51 Duplex SS
CB	CE3MN/5A/F53 Super Duplex SS
DY	CD3MVCuN/6A/F55 Super Duplex SS
FN	Inconel®
GC	LCC Low Temp. Steel
NB	Ni-Aluminium Bronze
SC	WCC Steel
TT	Titanium
CF	CF3/304L SS
CD	C12 Chrome Molybdenum
CN	CN7M Alloy 20
LC	LC3 Low Carbon Steel (-101°C)
MO	M35 Monel
CH	CW-12M Hastelloy C
FU	CU-5M CuC Inconel 825
FY	CY40 Inconel 600
FW	CW6MC Inconel 625
TF	B367 GR.C2 Titanium (F2)
TG	B367 GR.C3 Titanium (F3)
LT	LC4 Low Temp. 4-1/2% Ni Steel
LN	LC9 9% Nickel Steel
CR	CA6NM 18-1/2% Cr/Ni/Moly Steel
CL	WC4 Nickel Chromium Moly
CW	WC5 Nickel Chromium Moly
CM	WC11 Chromium Molybdenum
CO	C12 Chromium Molybdenum
CV	C12A Cr Molybdenum Vanadium
CS	CA15 Chromium Steel
Z	Special

* Body & plate are same material unless indicated by modifier suffix ⑪ indicating different plate material.

⑤ Seat	
A	EPDM
H	HNBR
E	Elast-O-Lion 985
J	Neoprene
L	Viton® AED
M	Buna/NBR
N	Nitrile
P	Metal*
R	Silicon
V	Viton® B
W	FKM
X	Viton® GLT
Y	Teflon®
Z	Special

* Modifier suffix ⑪ indicates special overlay materials. P Seat is 'as body' if no modifier suffix.

⑥ Ends	
F	Raised Face (serrated) B16.5
P	Plain Face
Q	Graylock® Hub
R	Ring Joint B16.5
S	Raised Face B16.47B*/API-605
T	Raised Face B16.47A* (MSS SP44)
U	Raised Face BS 3293*
V	Buttweld

* Over 600NB B16.5 Not applicable.

⑦ Body Type	
None	Wafer Style
(Blank)	
1	Lugged & Tapped
2	Lugged Through Bolt
3	Double Flanged Through Bolt
4	Double Flanged Tapped
5	Butt Weld
6	Hub Ends

⑧ NACE	
N	NACE
(Blank)	Non NACE

⑨ Spring Material	
2	Inconel® X750 Light Spring
3	316 SS Light Spring
4	316 SS
5	304 SS
6	Aluminium Bronze
8	Inconel® 600
9	Inconel® X750
0	Special

⑩ Other Trim Material (hinge pin, bearing, stop pin)	
1	304 SS
2	F55/UNS 32760
3	F51/UNS 31803
4*	316 SS
5	410 SS
6	Monel
7	F53/UNS 32750
8	AL-Bronze
9	A20
0*	Special

* 17-4 PH hinge pin option (other parts may be AS 316SS)

⑪ Modifier for Alternate plates (flaps) &/or seat overlay	
1	304 SS Plates
2	AL Bronze Plates
3	Ductile Iron Plates
4	316 SS Plates
4A	316 SS overlay Plates
5	316 SS Plates & Seat overlay
9	Stellite overlay Seat
39	410 SS Plates
40	410 Plates, Stellite overlay Seat
40A	410 Plates, Stellite Seat & Plates
41A	316 Plates, Stellite Seat & Plates
42B	316 Plates, Stellite overlay Seat
72A	WCB Plates, Stellite Seat & Plates
72B	WCB Plates, Stellite overlay Seat
98	304 Plates, Stellite overlay Seat
190	F51 Plates, Stellite Seat & Plates
191	F51 Plates, Stellite Seat
192	F55 Plates, Stellite Seat & Plates
193	F55 Plates, Stellite Seat
194	304 SS Plates, Stellite Seat & Plates
195	AL Bronze Plates, Stellite Seat & Plates
196	F53 Plates, Stellite Seat & Plates
197	F53 Plates, Stellite Seat
198	Ni-AL Bronze Plates, Stellite Seat
199	F51 Plates
200	Ni-AL Bronze Plates
201	F55 Plates
201	F53 Plates
203	Bronze Plates
204	Monel Plates
205	Monel Plates, Stellite Seat
999	Special

WAFER CHECK DUAL FLAP TUF-SKIN PN10 & PN16 RATED (1600 KPA)

Do away with expensive full SS bodied valves. The TUF-SKIN is factory bonded over all “wetted areas” i.e. in bore & full faces Viton or EPDM or teflon over entire valve with S/S or A-Bronze trim. The external body can be epoxy coated. Only the outer body is iron, even the flange faces are fully encased by the liner. R in front of figure # denotes Rubber Check Tuf-Skin design. This design gives a much larger and together seating area for better seal and longer life. Also ideal where even stainless steel is subject to corrosion. This design prevents eventual leakage of o-ring seals normally used in soft seated duo-checks and also provides superior seal on flange contact area. The seat and flange face are both ribbed for superior sealing.

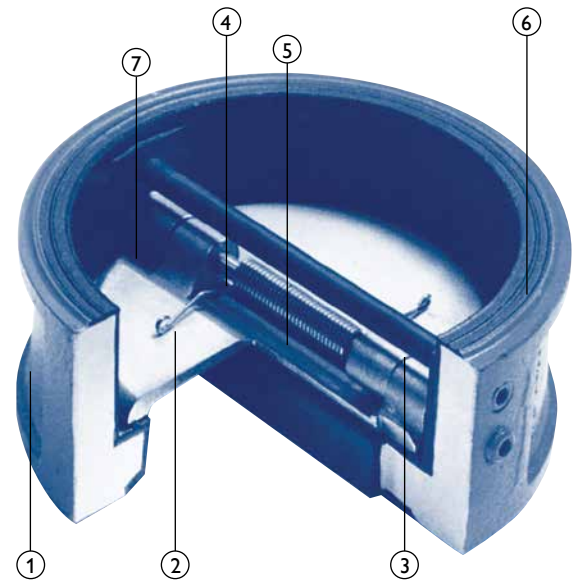

20 Bar Also Available

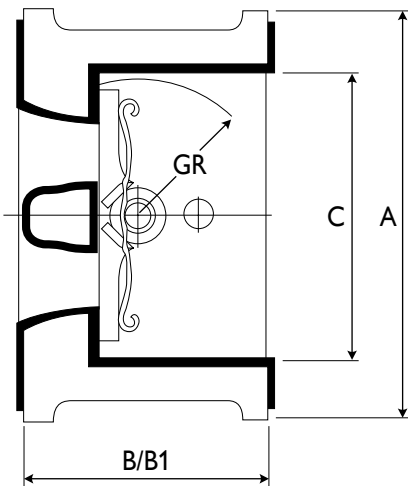

Part No.	Part Name		Material		
			JIS	ASTM	
1	Body	10K	150P	FC200	A126-B
		20K		FCD450	A536
2	Disc		SCS13	A351-CF8	
3	Stop Pin		SUS304	A182 F30	
4	Hinge Pin		SUS304	A182 F304	
5	Spring		SUS316	A182 F316	
6	Rubber Seat		BUNA-N(NBR), EPDM, TEFLON		
7	Washer		TEFLON		

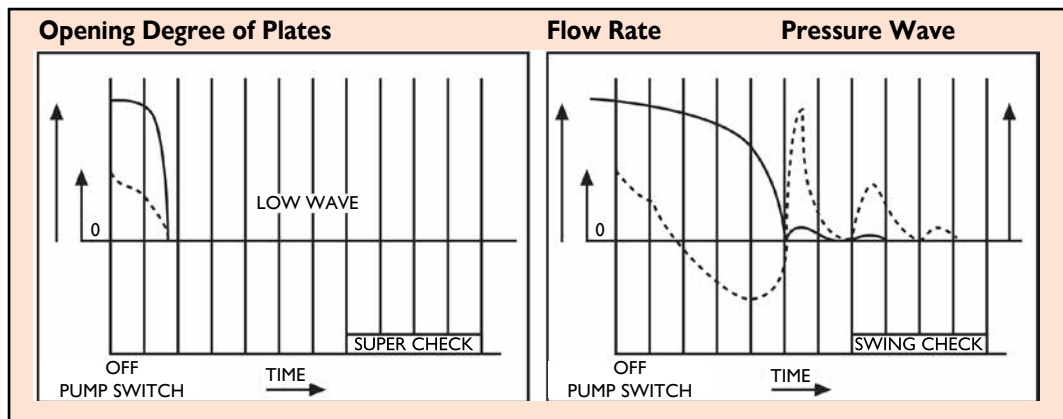

WAFER CHECK SINGLE FLAP LONG PATTERN LARGE PORT SLP/SW SERIES

The SLP and SW Unichek Swing Check Valve is available up to 700mm in various body materials and dimensions. The SW Series is retainerless. The SLP and SLP-T is non retainerless design and lends itself to applications requiring limit/micro switches, counter weights etc. The SLP and SW flapper has spring assisted closing, suitable for horizontal or upwards vertical service (downwards requires an external closing spring, which is an available option only in SLP and SLP-T Series). Design is to API 594 face to face dimension generally in accordance with ASME B16.10 short pattern/ API 6D long pattern and tested to API 598/ISO 5208. The SLP/SW series has a large bore providing a larger flow when compared to dual flap style or slim line uniflap checks. The SLP and SW 125 Class is ideal for waterworks & chemical service, whilst the 150 up to 1500 Class range is suitable for oil and gas service & has an intrinsically firesafe design.

RESILIENT 'O' RING SEAT FEATURES SLP/SW

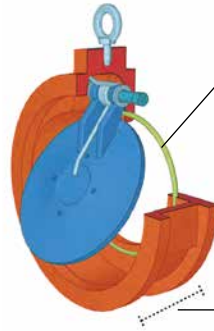

Resilient, Soft Seat coupled with precision encapsulated machined sealing surfaces ensure a bubble tight seal (Metal seat available)

Economical Design provides a highly efficient check valve with a larger port than dual flap valves that is inexpensive and has a short laying length.

1. A truly dynamic seal, mechanically contained in a specially designed groove.
2. Unique in design and application.
3. As pressure is applied to the valve disc, the seal is compressed into the groove, ensuring a consistent and uniform seal.
4. The load on the seal is controlled reducing wear for longer life. Metal seated is also available.

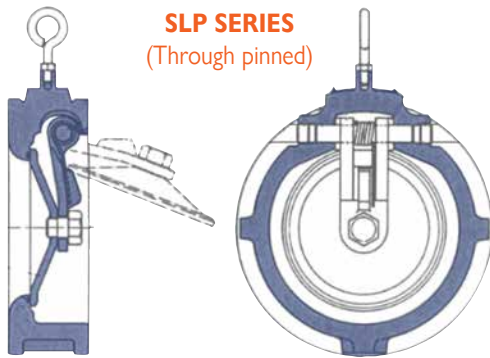

SLP SERIES
(Through pinned)

Light and strong

Supercheck SLP/SW series valves are light, so line stress is reduced to a minimum. Yet the installed valve assembly is more rigid than an equivalent length of heavy-walled pipe.

Smooth, fully automatic operation

The SLP/SW series valves are designed to be fully automatic in function. The smooth opening and closing action reduces line hammer to a minimum. SLP/SW series valves are engineered to present an essentially unobstructed orifice.

Simplified design

The SLP/SW series are made with a minimum of parts. The stainless steel trim and resilient 'O' Ring seat (soft seat version) ensures long life. The single 'O' Ring ensures a complete leak-free seal.



SWING STYLE (SLP)

SLP SERIES
(Retainer Type)



TILT STYLE (SLP-T)

LARGE PORT SIZE

Inlet ports and disc have been shape optimized to achieve a fully open position at low flow rates. Therefore, the SLP/SW series operates exceptionally well in the flow rates typically found in pipeline containing control valves and lines with varying media flows.

Compare the SLP/SW series to typical full-sized swing check valves. Due in part to their oversized, heavier discs, these valves only fully open at larger flow rates. When activated at a lower flow rate, these valves lose true controllability and do not fully open. A partially open disc creates an obstruction that produces a higher pressure drop and fluttering of the disc valve - disturbing the flow & increasing the chance of water hammer.

SLP/SW Series will eliminate or reduce these problems.



SWING STYLE (SW)

SW SERIES
(Retainerless)



TILT STYLE (SW-T)

SW SERIES

DESIGN & PERFORMANCE STANDARD SERIES SW RETAINERLESS

PERFORMANCE STANDARD

- ANSI B16.5 [1.5" up to 24"] - Flange Dimension
- API 6D/ANSI B16.10 - Face to Face Dimension
- API 598/ISO 5208 - Testing, allowable leakage rate
- ANSI B16.34 - Wall Thickness

RETAINERLESS DESIGN

The SW Series unique design doesn't have a shaft hole bored through the body wall, unlike many competitors. This unique design prohibits any possibility of shell leakage and makes the valve inherently fugitive emission by design.

SW SERIES
(Retainerless)

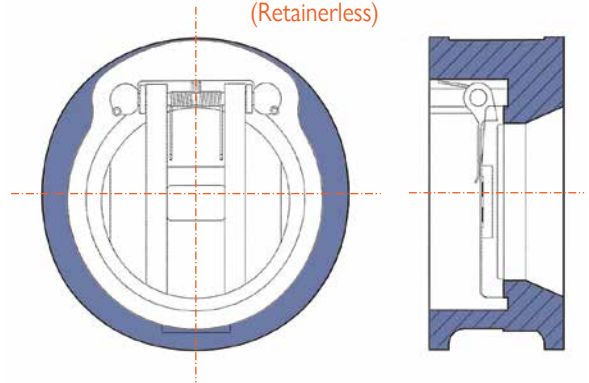

SW SERIES
(Retainerless)



SW COMPONENTS		
SP01	Body	
SP02	Disc	
SP03	Insert	
SP04	Hinge Pin	
SP05	Spring	
SP06	Washer	
SP07	Set Screw	

SW SERIES
(Retainerless)

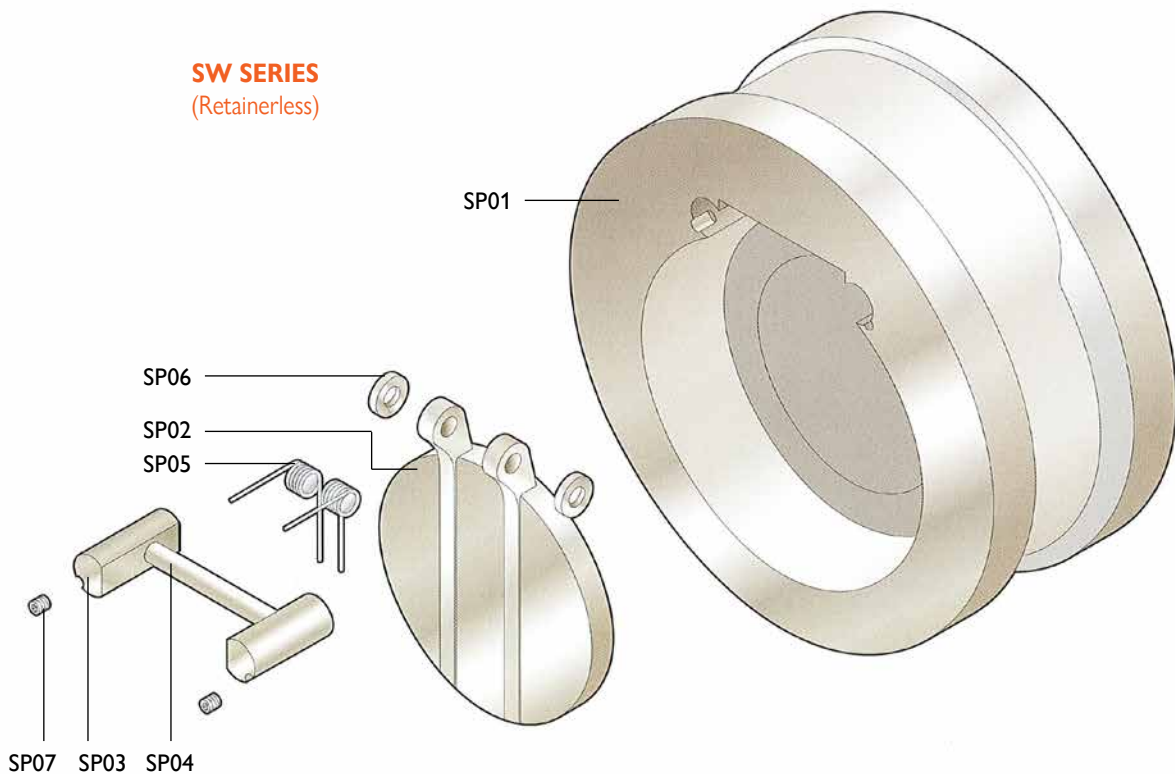

SLP/SW SERIES

WAFER SWING BODY DIMENSION FOR SLP/SW

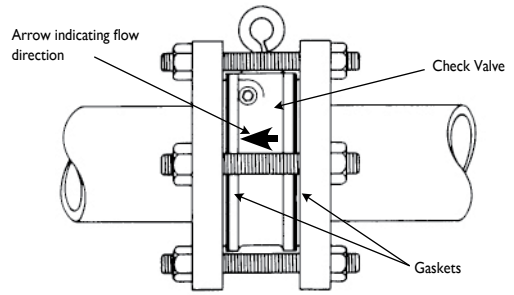
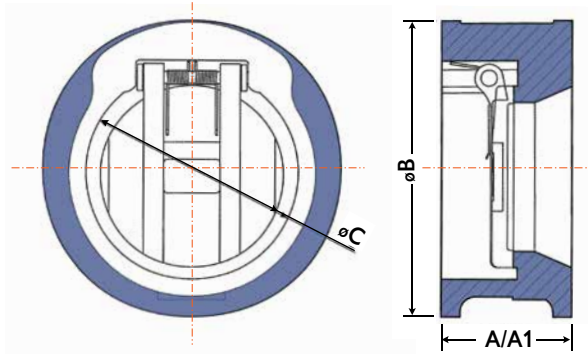
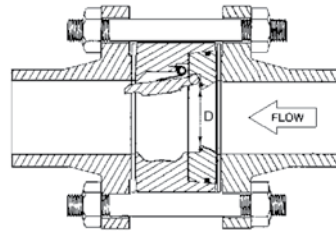
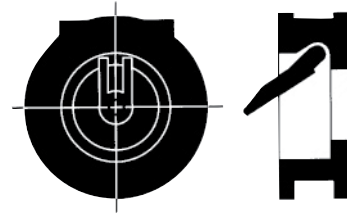

Dimensions* SLP/SW (150/300 CLASS*)							Bolting			
Size in (mm)	ANSI Rating	End Facing	A† (mm)	A1 (mm)	B (mm)	C (mm)	Qty	Dia (mm)	Length (mm)	Weight Kg
1.5 (40)	150	RF		51	67	46	4	13	2-3/4	2.0
	300	RF		51	73	46	4	19	3-1/2	2.2
2 (50)	150	RF	60	44	104	57	4	16	152	2.3
	300	RF	60	44	111	57	4	16	152	3.2
3 (80)	150	RF	72	51	137	82	8	16	178	4.1
	300	RF	72	51	149	82	8	19	207	5.9
4 (100)	150	RF	72	57	175	110	8	16	178	8.6
	300	RF	72	57	181	110	8	16	178	12.8
6 (150)	150	RF	97	70	222	158	8	19	203	13
	300	RF	97	70	250	158	12	19	245	16.2
8 (200)	150	RF	125	73	279	180	8	19	248	23
	300	RF	125	73	308	180	12	22	286	32.1
10 (250)	150	RF	146	79	340	241	12	22	279	43
	300	RF	146	79	362	241	16	25	324	24.3
12 (300)	150	RF	181	86	410	314	12	22	311	71
	300	RF	81	86	422	314	16	29	372	80.9
14 (350)	150	RF	184	108	451	336	12	25	330	81.6
	300	RF	222	222	486	336	20	29	419	102.7
16 (400)	150	RF	191	108	514	390	16	25	343	104
	300	RF	232	232	540	390	20	32	441	187.9

* Class 600 to 1500 available from 1" (25mm) to 16" (400mm) refer to drawing.
 † Face to face dimension A is API 594, A1 is to ANSI/ASME B16.10 Short Pattern

SLP/SW SERIES



HIGH FLOW CAPACITY

The SLP/SW Series valves elliptical shaped inlet and optimum diameter, plus its virtually unobstructed opening combine to produce a substantially higher flow capacity (Cv) than other wafer check valves.

REDUCED WATER HAMMER

The design of the SLP/SW Series will largely reduce or eliminate water hammer by closing the valve at the right moment (before reverse flow occurs).

PRESSURE DROP WITH WATER

Valve Size inch / mm	Cv	Min Flow to Fully Open Valve		Approx Pressure Drop w/Water PSI
		GPM	Ft./sec.	
1 / 25	30	28	10.4	0.78
1.5 / 40	38	68	10.7	2.1
2 / 50	84	46	4.4	1.7
2.5 / 65	137	76	5.1	1.4
3 / 75	221	197	8.5	1.1
4 / 100	373	157	4.0	1.4
5 / 125	679	352	5.6	1.1
6 / 150	931	367	4.1	1.5
8 / 200	1440	428	2.7	1.6
10 / 250	2623	837	3.4	1.1
12 / 300	3531	1229	3.5	1.2
14 / 350	3226	1180	2.7	2.0
16 / 400	3911	1447	2.5	2.6
18 / 450	5799	3376	4.8	1.7
20 / 500	7769	6500	6.3	1.5
24 / 600	10105	8321	5.9	1.6
28 / 700	14100	9250	5.3	1.5
30 / 750	18041	10303	5.1	0.9
32 / 800	20900	12150	5.0	1.4
36 / 900	25675	15850	5.2	2.0
40 / 1000	39340	25310	6.1	2.4
42 / 1050	47914	31304	7.5	2.7
48 / 1200	44983	33095	5.9	1.6
54 / 1350	63000	45000	6.0	0.9
60 / 1500	70500	62800	6.2	1.1

Full open stable minimum velocity and the efficiency calculated at a normal velocity of 10 f/sec.

SLP/SW PART NUMBER CODE

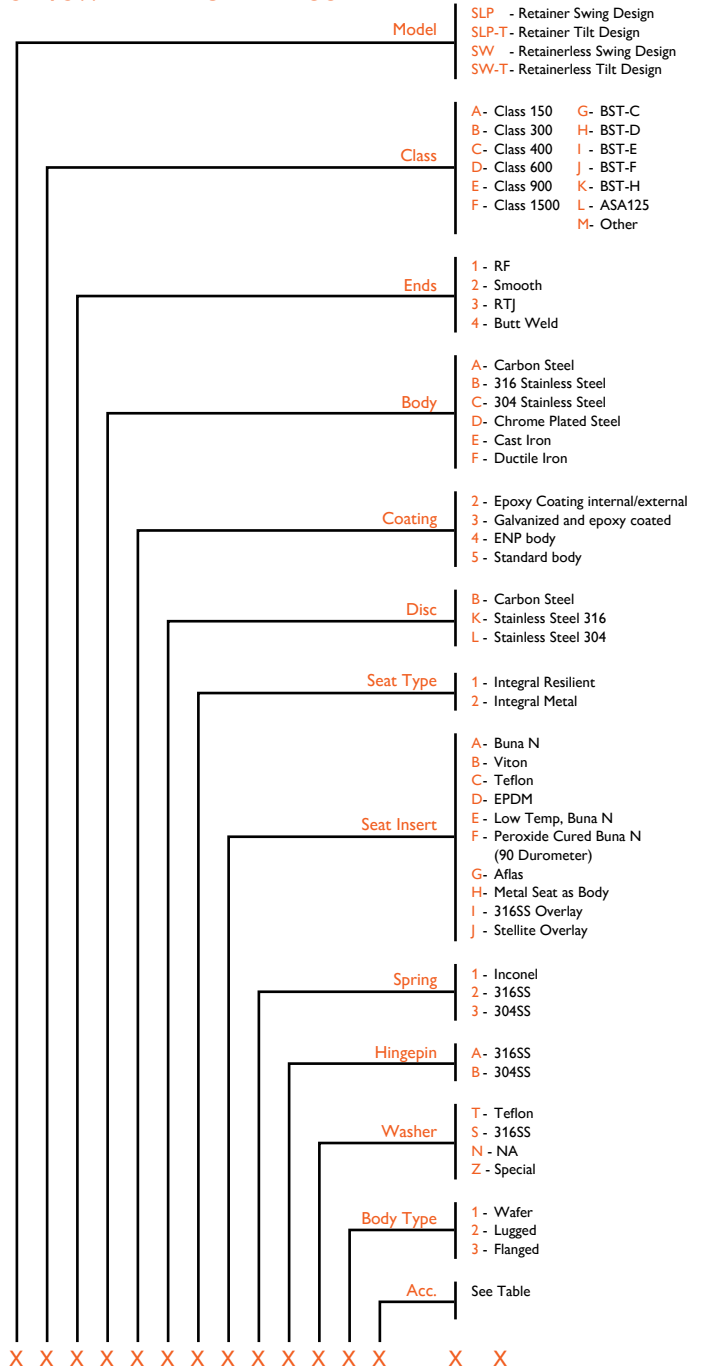

SPECIAL APPLICATION ACCESSORIES

A0	Eternal Spring
A1	External Spring & Weight
A2	Limit Switch
A3	Backflush Lever and Eternal Spring
A4	External Position Indicator
A5	Backflush Lever
A6	Emergency Shut-off, Fusible Link
A7	Dual Balanced Weights
A8	External Weight
A9	External Compression Spring
B1	External Compression Spring and Weight
B2	External Spring, Weight, Hydraulic Damper
B3	External Compression Spring, Weight & Hydraulic Damper
-	Other

NON SLAM AXIAL PISTON DISC CHECK MODEL NSSLSC - PN40

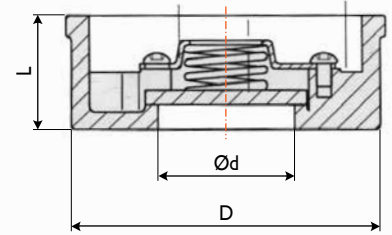
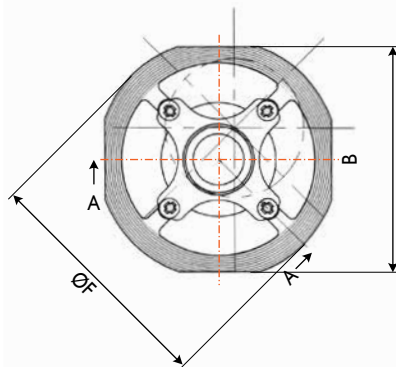

FEATURES PN40 VERSION

- Full Flow Piston Check
- Face to face conforms to DIN 3203 part 3-k4
- Investment casting
- PN20, PN40 DIN 3202 K5, DIN 3202 K4
- Standard configuration only suitable for liquid service. Consult us if you use for air/gas service.

No.	Parts	Stainless Steel	Qty
1	Body	ASTM A351-CF8M/1.4408	1
2	Cap	AISI 316	1
3	Disc	AISI 316	1
4	Spring	AISI 316	1
5	Screw*	AISI 316	4

*5 & ABOVE INTEGRAL NO SCREW

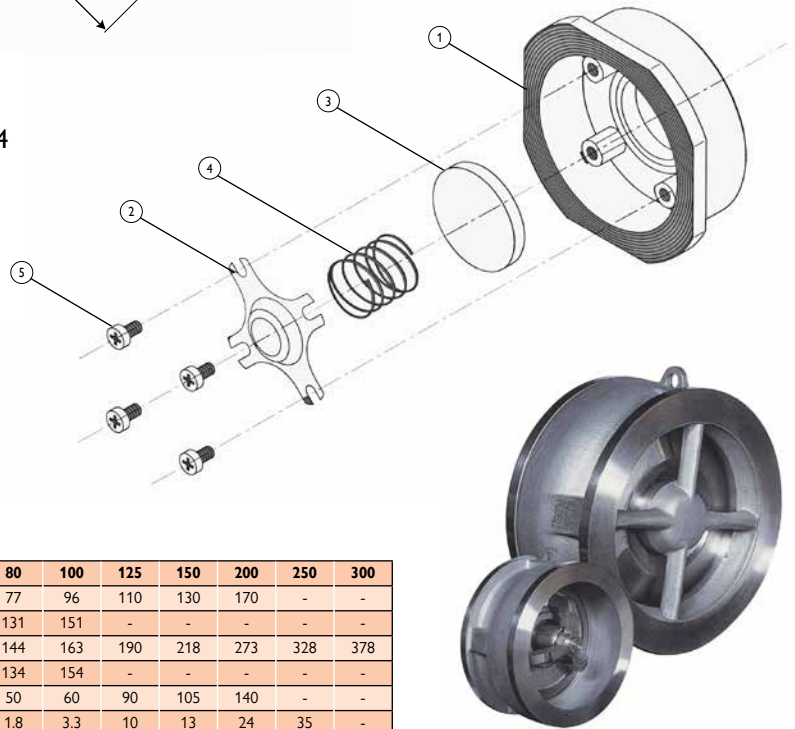

SIZE/DN	15	20	25	32	40	50	65	80	100	125	150	200	250	300
Ød	15	20	25.4	30	38	47	62.5	77	96	110	130	170	-	-
D	43	53	63	75	86	95	115.0	131	151	-	-	-	-	-
ØF	53	63	73	84	94	107	126.0	144	163	190	218	273	328	378
B	45	55	65	78	88	98	118.0	134	154	-	-	-	-	-
L	16	19	22	28	32	40	46.0	50	60	90	105	140	-	-
KG	0.12	0.2	0.3	0.4	0.6	1.0	1.6	1.8	3.3	10	13	24	35	-

LOSS OF PRESSURE DIAGRAM H₂O AT 20°C

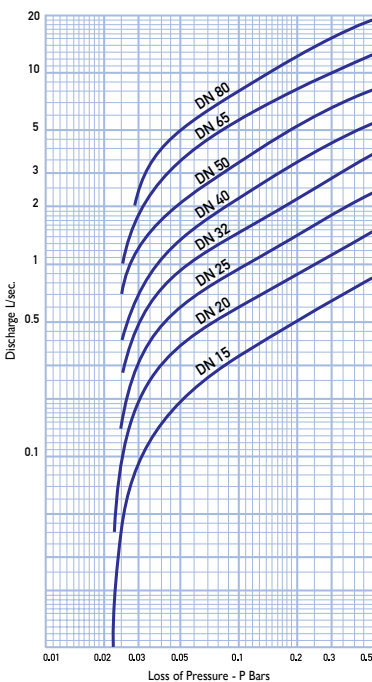

LOSS OF PRESSURE DIAGRAM H₂O AT 20°C

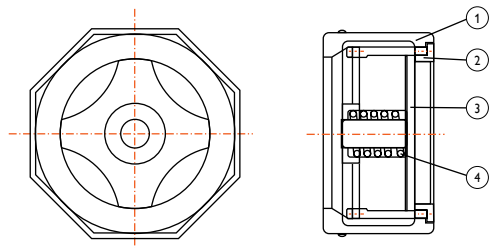
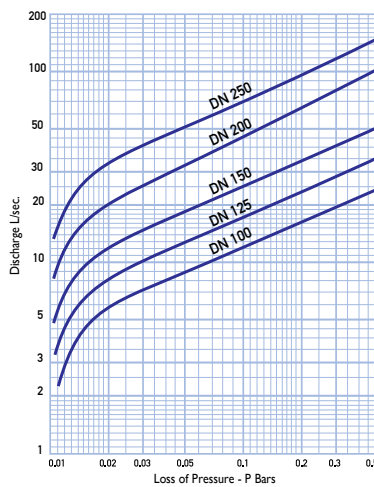

BILL OF MATERIAL WITH SEAT INSERT*				
CODE	BODY	SPRING	SEAT*	DISC
	A105	AISI 316	AISI 316	AISI 316
	1	4	3	2

* SOME SIZES HAVE INTEGRAL SEAT



MODEL NSSLSC - PN40

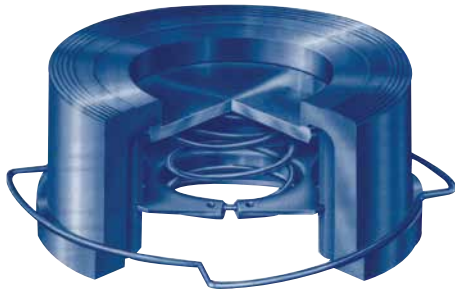

SC01, DN 15-100 mm (1/2"-4") with special centering ring (optional)

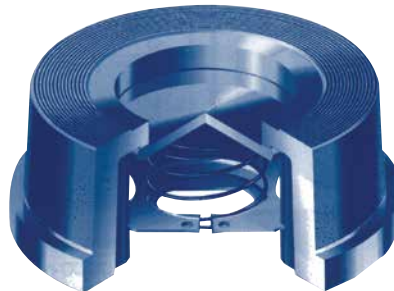

SC02, DN 15-100 mm (1/2"-4") with self-centering body

DEGREE OF OPENING

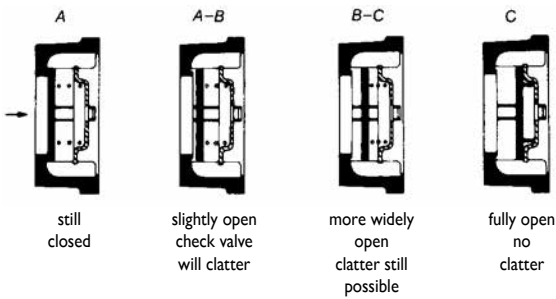

still closed slightly open check valve will clatter more widely open clatter still possible fully open no clatter

Degree of opening of a spring-assisted non-return valves as a function of volume flow

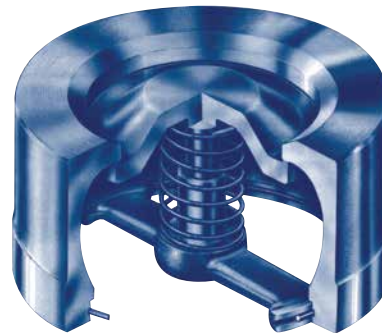

SC03, DN 125-200 mm (5"-12") (Stem guided piston check)

Required cracking pressure Mbar

DN 15	25	21	23
-------	----	----	----

DN 20	25	21	23
-------	----	----	----

DN 25	25	21	23
-------	----	----	----

DN 32	27	21	24
-------	----	----	----

DN 40	29	21	25
-------	----	----	----

DN 50	29	21	25
-------	----	----	----

DN 65	31	21	25
-------	----	----	----

DN 80	32	21	26
-------	----	----	----

DN 100	83	21	27
--------	----	----	----

PARTS MATERIALS

Body	WCB	ZG1Cr18Ni9Ti	SS304	SS304L	ZG1Cr18Ni12M02Ti	SS316 (1.4408)	SS316L
Disc & Seat	2Cr13	ZG1Cr18Ni9Ti	SS304	SS304L	ZG1Cr18Ni12M02Ti	SS316	SS316L
Spring	4Cr13	1Cr18Ni9Ti-L	0Cr18Ni9-L	00Cr19Ni11-L	1Cr18Ni12M02Ti-L	0Cr17Ni12M02-L	00Cr17Ni14Mo2-L
Shaft	2Cr13	1Cr18Ni9Ti-L	0Cr19Ni11 (304)	00Cr19Ni11 (304L)	1Cr18Ni12Mo2T1	0Cr17Ni12M02(316)	00Cr17Ni14M02 (316L)
Temp.*	-29°C ~300°C*		-196°C ~300°C*				

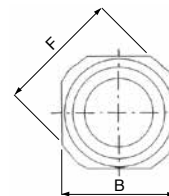

PTFE & PP BODY ALSO AVAILABLE

* Absolute maximum range at 0 PSI and dependent upon materials and trim. Up to 400°C possible depending on spring. However, severe pressure limitations apply as temperature increases (400°C limit is zero PSI)

DIMENSIONS AND WEIGHT

Class		150*			300*			600			900			PN40			
in	mm	Thickness	OD	Weight (Kg)	Thickness	OD	Weight (Kg)	Thickness	OD	Weight (Kg)	Thickness	OD	Weight (Kg)	Thickness	B	F	Weight (Kg)
1/2	15	16.0	47	0.2	25.0	53	0.23	25	53	0.25	25	63	0.3	16	45	53	0.1
3/4	20	19.0	57	0.3	31.5	65	0.36	31.5	65	0.38	31.5	69	0.4	19	55	63	0.2
1	25	22.0	66	0.45	35.5	72	0.52	35.5	72	0.55	35.5	78	0.6	22	65	73	0.3
1-1/4	32	28.0	75	0.6	40.0	81	0.75	40	81	0.8	40	88	1	28	78	84	0.4
1-1/2	40	31.5	85	0.8	45.0	95	1.1	45	95	1.2	45	98	1.5	32	89	94	0.6
2	50	40.0	103	1.2	56.0	110	1.95	56	110	2	56	142	2.5	40	98	107	1.0
2-1/2	65	46.0	122	1.9	63.0	129	2.9	63	129	3	63	164	4	46	118	126	1.6
3	80	50.0	136	2	71.0	148	5.5	71	148	6	71	167	8	50	134	144	1.8
4	100	60.0	175	4	80.0	180	9	80	192	10	80	205	13	60	154	163	3.3
5	125	90.0	196	10	110.0	215	15	110	240	17	110	247	20	90	-	190	10
6	150	106.0	222	13	125.0	250	20	125	265	22	125	288	25	105	-	218	13
8	200	140.0	279	24	-	-	-	-	-	-	-	-	-	140	185	273	24
10	250	150.0	340	35	-	-	-	-	-	-	-	-	-	150	266	-	35
12	300	160.0	410	50	-	-	-	-	-	-	-	-	-	160	410	-	50

*PN40 will multi fit ANSI 150 & ANSI 300

NON SLAM NOZZLE CHECK VALVE SW-NC/FL-NCFO SERIES

DESIGN FEATURES

- Design to API 6D and Face to Face Distance as per manufacturer's standards.
- Fast acting spring prevents water hammer and pressure surge, this is a truly Non Slam Check Valve.
- Short Travel and Ultra Light weight Disc make the advantages of Non Slam Check Valves possible & reduces water hammering. Quick closing and fast travelling disc are the fundamental design features.
- High Velocity and Gas Flow under compressed conditions can reach sonic velocity and the 'sonic booms' are detrimental to the valves operation. The simple but precisely calculated spring design overcomes this problem.
- Bernoulli's equation of conservation of energy is the solution for spring design. Velocity head exchanges the energy with Pressure Head and the Supercheck Non Slam Check keeps on performing without the fear of sonic boom and valves offer low Pressure Drop when compared to Dual Plate Check Valves static pressure. Dropping the velocity head at vena contracta increases static pressure reducing cavitation.
- Single piece body construction allows High Pressure Applications and Non Slam Nozzle Check Valves are inherently Fire Safe.

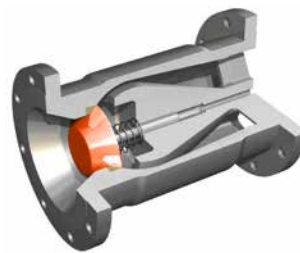

PRODUCT RANGE

- **Rating** ANSI Class 150, 300, 600, 900, 1500 & 2500 & up to 10,000 psi.
- **Material** ASTM A105, A182, Gr. LF2, Gr. F316, Gr. F51, Gr. F55 etc.
- Designed using Computational Fluid Dynamics (CFD)
- Low head loss & minimum pressure loss can be achieved.
- Metal to Metal seated design.
- Conical seating surface is self aligning & provides tight shut off.
- Spring loaded disc design allows mounting in any orientation.

CHARACTERISTICS

- Non Slam Closure
- Extremely quick Closure
- Low Pressure Loss
- Short stroke of disc
- Axial movement of disc
- Disc's minimal wear characteristics

APPLICATIONS

- Chemical, Oil & Gas Industries
- Residual Heat Removal Systems
- Nuclear Power Plants
- Offshore & Onshore Production Platform, FPSO
- Containment Isolation
- Water, Steam, Gas, Vacuum
- Steam Injection Systems
- Power Station, Water Pumping Stations
- Natural Gas, Refineries
- Critical Equipment Discharge
- Gas Compressor Unit
- Cracker Plants

FL-NCFO Series

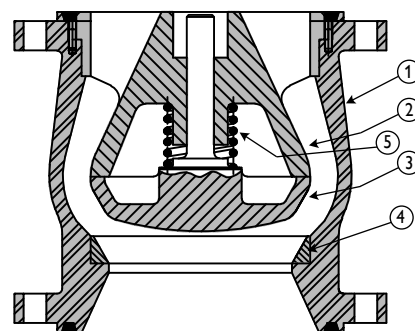

- 1 Body
- 2 Diffuser
- 3 Disc
- 4 Seat
- 5 Spring

INSTALLATION

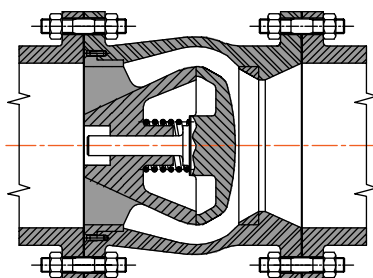

NOZZLE CHECK VALVE FLANGED END
FLOW

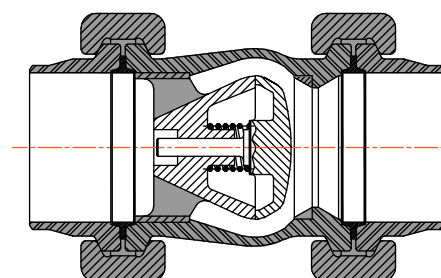

NOZZLE CHECK VALVE HUB END
FLOW

SW-NCA & NCB SERIES

OPEN SW-NCA Series

CLOSED SW-NCB Series

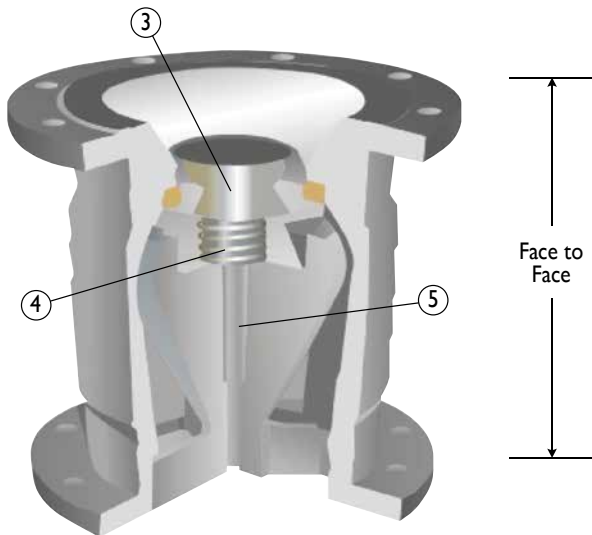
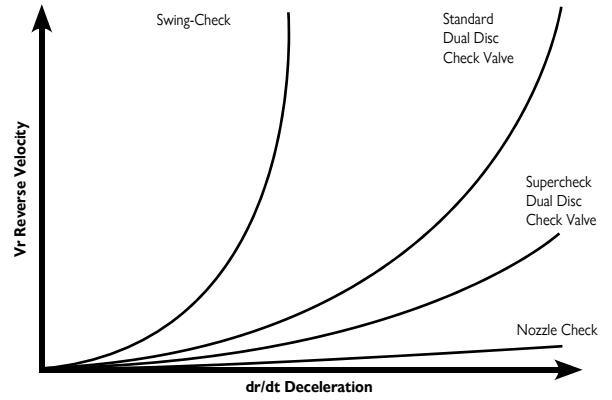
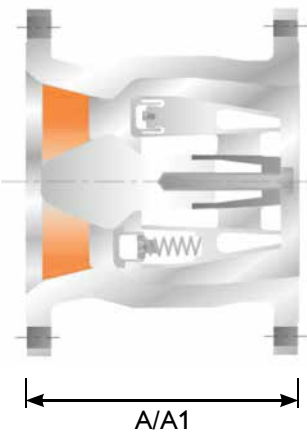
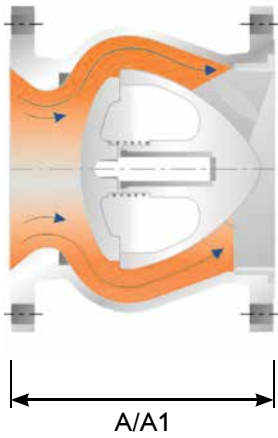

**Single Spring Loaded Nozzle Check Valve
SW-NCA Series**

Up to 250NB (10") and 150~300LBS single spring loaded design (Model Number: SW-NCA) minimum pressure loss with excellent dynamic performance.

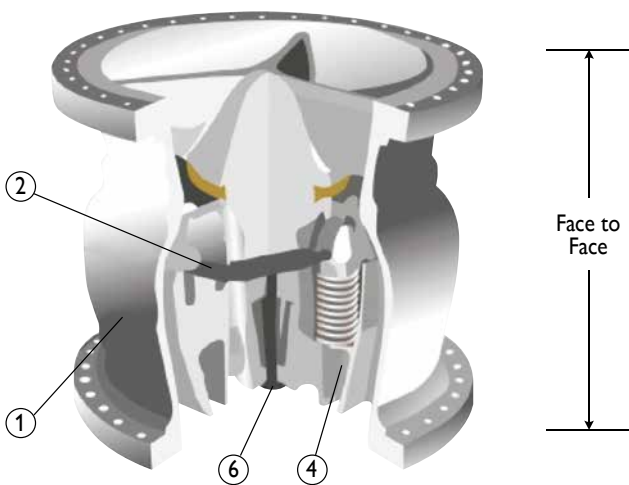

**Multi Spring Loaded Nozzle Check Valve
SW-NCB Series**

250NB (10") and above 150~2500LBS multi spring loaded design (Model Number: SW-NCB) minimum pressure loss with excellent dynamic performance.

Example Only. Refer to as built drawings. (FL-NCFO Series) also refer to drawings as all dimensions are different.

SW-NCA & NCB SERIES DIMENSIONS

ANSI INSTALLATION DIMENSIONS

Dimension for larger valve sizes available upon request. Also available with JIS, DIN, BN, AS and ISO dimensions. API 2000, 3000, 5000, 10000 also available.

Supercheck Nozzle Check valve is designed to meet the criteria of conventional check valves by allowing forward flow under normal conditions, opening easily and firmly backseating at low velocity.

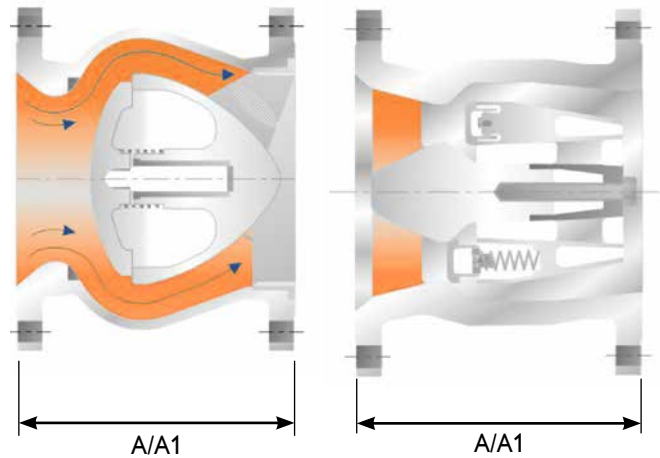

FACE TO FACE DIMENSIONS

ANSI 150		SW-NCA Single Spring					SW-NCB Multi Spring								
Size	in	2	4	6	8	10	12	14	16	18	20	24	28	30	36
	mm	50	100	150	200	250	300	350	400	450	500	600	700	750	900
Short Pattern A	in	4.49	8.98	13.07	15.12	16.81	17.32	18.70	19.69	22.24	27.17	30.24	35.43	36.54	40.67
	mm	114	228	332	394	427	440	475	500	565	690	768	900	928	1033
	kg	6	21	38	118	198	254	312	373	484	965	1179	1404	1768	2344
Long Pattern A1	in	7.99	11.50	14.02	19.49	24.49	27.52	30.98	34.02	38.50	38.50	50.98	57.01	60.00	77.01
	mm	203	292	358	495	622	699	787	864	978	978	1295	1448	1524	1956
	kg	11	43	68	175	219	257	385	440	733	1037	1297	1805	2211	2443

ANSI 300		SW-NCA Single Spring					SW-NCB Multi Spring								
Size	in	2	4	6	8	10	12	14	16	18	20	24	28	30	36
	mm	50	100	150	200	250	300	350	400	450	500	600	700	750	900
Short Pattern A	in	4.69	9.33	13.58	15.12	17.32	17.48	19.05	19.69	22.24	27.17	30.24	35.43	36.54	40.67
	mm	119	237	345	394	440	444	484	500	565	690	768	900	928	1033
	kg	8	36	68	147	226	274	400	477	621	981	1233	1980	2155	3303
Long Pattern A1	in	10.51	14.02	17.52	20.98	24.49	27.99	32.99	39.02	42.99	47.01	55.00	62.99	65.00	82.01
	mm	267	356	445	553	622	711	838	991	1092	1194	1397	1600	1651	2083
	kg	12	43	86	184	251	298	534	582	738	1056	1363	2148	2380	3922

Example Only. Refer to as built drawings. (FL-NCFO Series) also refer to drawings as all dimensions are different.



AUSTRALIAN PIPELINE VALVE®

COMPLETE PRODUCT LINE

“Australian Pipeline Valve produces isolation, control and flow reversal protection products for severe and critical service media in utility, steam, pipelines, oil & gas and process industries. APV valves and pipeline products form the most competitive portfolio in the market.”



SUPER-CHECK®



TORQTURN®

TWIN-LOK®

UNIFLO®



AUSTRALIAN PIPELINE VALVE BRAND RANGE - CATALOGUES

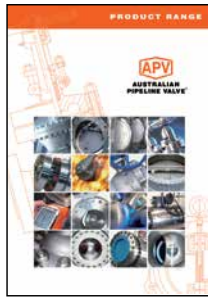

Product Brochure



Ball Valves Floating & Trunnion Mounted

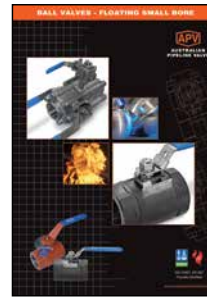

Ball Valves Floating Small Bore

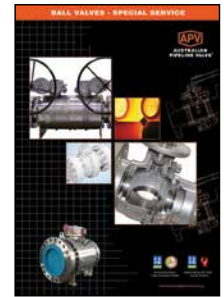

Ball Valves Special Service



Gate, Globe & Check Valves - Cast Steel



Gate, Globe & Check Valves - Forged Steel

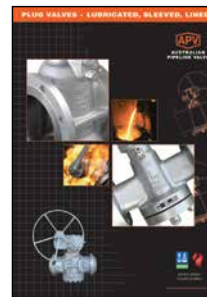

Plug Valves Lubricated, Sleeved & Lined

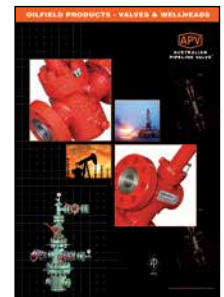

Oilfield Products Valves & Wellheads

APV FAMILY OF BRANDS RANGE - CATALOGUES



Diamond Gear Gearboxes



Flowturn Ball Valves Multiway & Deadman



Flowturn Gate, Globe & Check Valves



Flowturn Instrument Valves

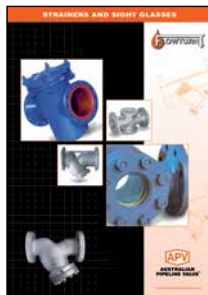

Flowturn Strainers & Sight Glasses



Steamco Steam Valves



Supercheck Wafer Check Valves



Superseal Butterfly Valves

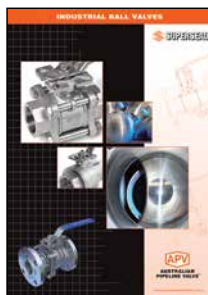

Superseal Industrial Ball Valves



Torqturn Actuators

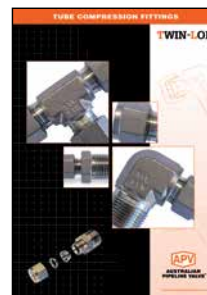

TwinLok Tube Fittings

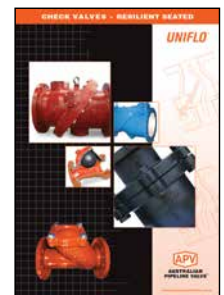

Uniflo Check Valves

Contact us for your local stockist/distributor



AUSTRALIAN PIPELINE VALVE®

ADELAIDE • BRISBANE • PERTH

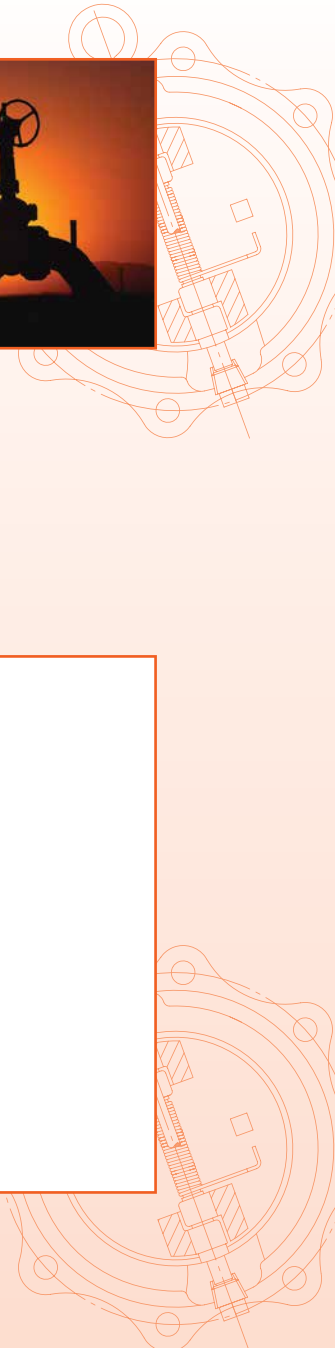

www.australianpipelinevalve.com.au

LOCAL DISTRIBUTOR



QUALITY ASSURANCE AND CERTIFICATION

We are continually improving all facets of quality assurance. Full metallurgical and test certificates are always supplied for all pressure retaining parts, we also provide it on all major trim components.

We have endeavoured to provide a broad outline of our range and capabilities. Because we are continually developing new products for our customers this catalogue will, to some extent be incomplete. This catalogue is a general overview only, individual drawings and data sheets can be furnished on request.

If you have any requirement in the field of valves, please contact us for a prompt response. Continuous development of Australian Pipeline Valve products may necessitate changes in the design or manufacturing processes. Australian Pipeline Valve reserves the right to effect any such changes without prior notice.

