

CAST STEEL STEAM VALVES

SHORT VERSION

[Click here](#) for complete version of this catalogue

STEAMCO®

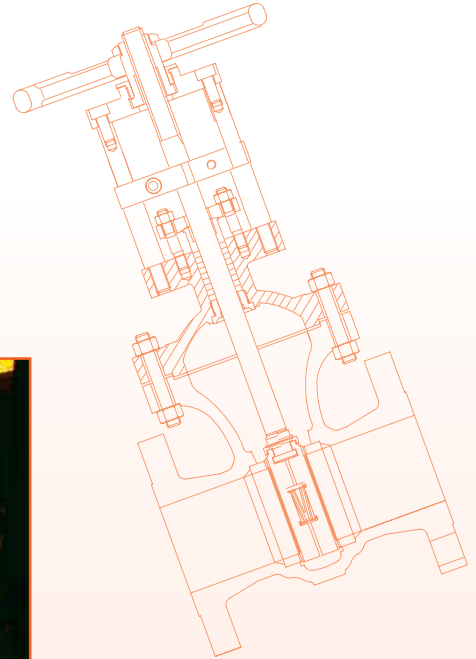

API 622 2011 2nd Edition
Fugitive Emission Certified



**AUSTRALIAN
PIPELINE VALVE®**

www.australianpipelinevalve.com.au

QUALITY VALVE MANUFACTURER

QUALITY COMMITMENT

Quality is Our First Priority.

Consistent product quality and a proven track record makes Australian Pipeline Valve a dependable choice where total reliability is the number one concern.

Since its founding, APV's philosophy has been focused on quality. Our valves are manufactured in full compliance to worldwide standards (such as ASME/ANSI, API, EN, ISO, BS, AS).

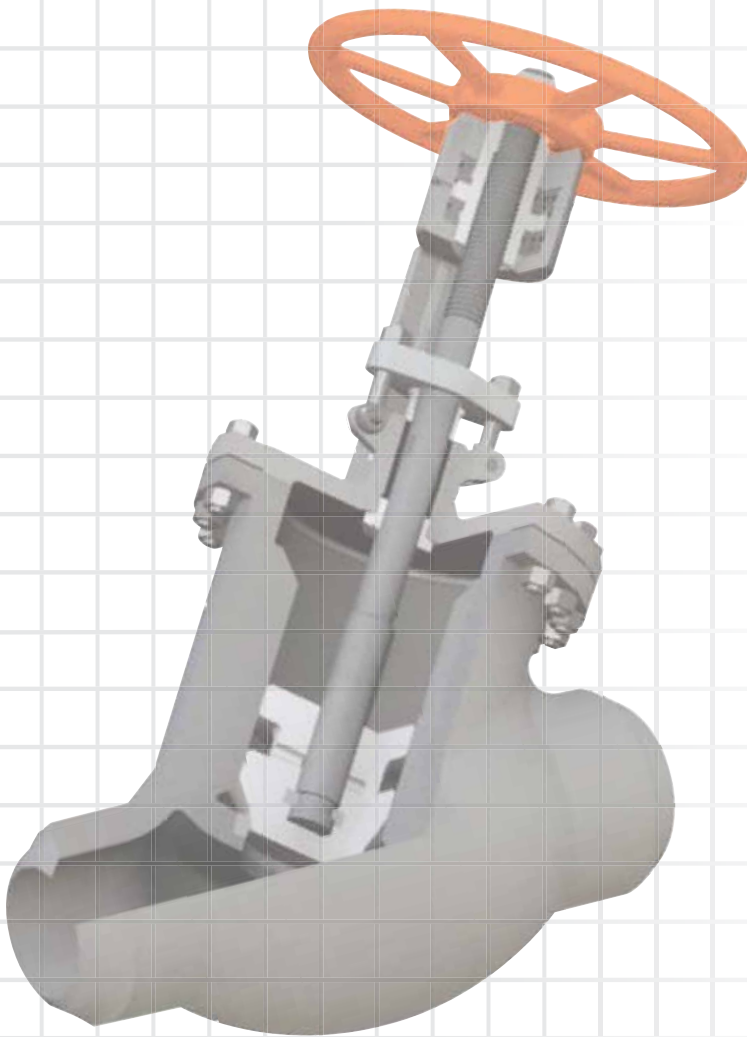

**AUSTRALIAN
PIPELINE VALVE®**

70-78 Stanbel Road Salisbury Plain South Australia 5109

Telephone +61 (0)8 8285 0033

email: admin@australianpipelinevalve.com.au

CONTENTS

Figure Number System	4~5*
Physical & Chemical Properties	6*
Gate Valve - Parallel Slide - Class 150-2500	7~15*
Blowdown Valve - Parallel Slide	16~17
Gate Valve - Parallel Slide - Class 150-2500 - Cast Steel	18~19*
Gate Valve - Geothermal Trim	20~21
Globe Valve - Stop Check - Class 150-600	22~23*
Globe Valve - Cast Steel	24*
Globe Valve - Y Pattern Inclined Bonnet Stop Check - Class 150-600	25~26*
Globe Valve - Right Angle - Class 150-600	27~28*
Combination Y Globe/Stop/Check/Strainer	29*
Y Type Stop Check Valve Screwed Ends	30*
Globe Valve - Piston Type - PG01-PG02	31~32
Non Return Piston Check - Lift Type - Class 150-600	33~35*
Globe Valve - Bellow Sealed - Bolted Bonnet	36
Gate Valve - Bellow Sealed - Bolted Bonnet	37
Steam Jacketed Ball Valve Wafer Style	38*



© Copyright Australian Pipeline Valve 1990 - 2023 Edition

Catalogues, photos, brochures and technical publications are the exclusive property of Australian Pipeline Valve. Any unauthorised reproduction in total or in part, shall result in prosecution. Products and data sheets in this publication are subject to change at anytime without notice. Australian Pipeline Valve reserves the right to carry out amendments to products and materials.

PARALLEL SLIDE GATE VALVE

CAT P316S CLASS 150-900

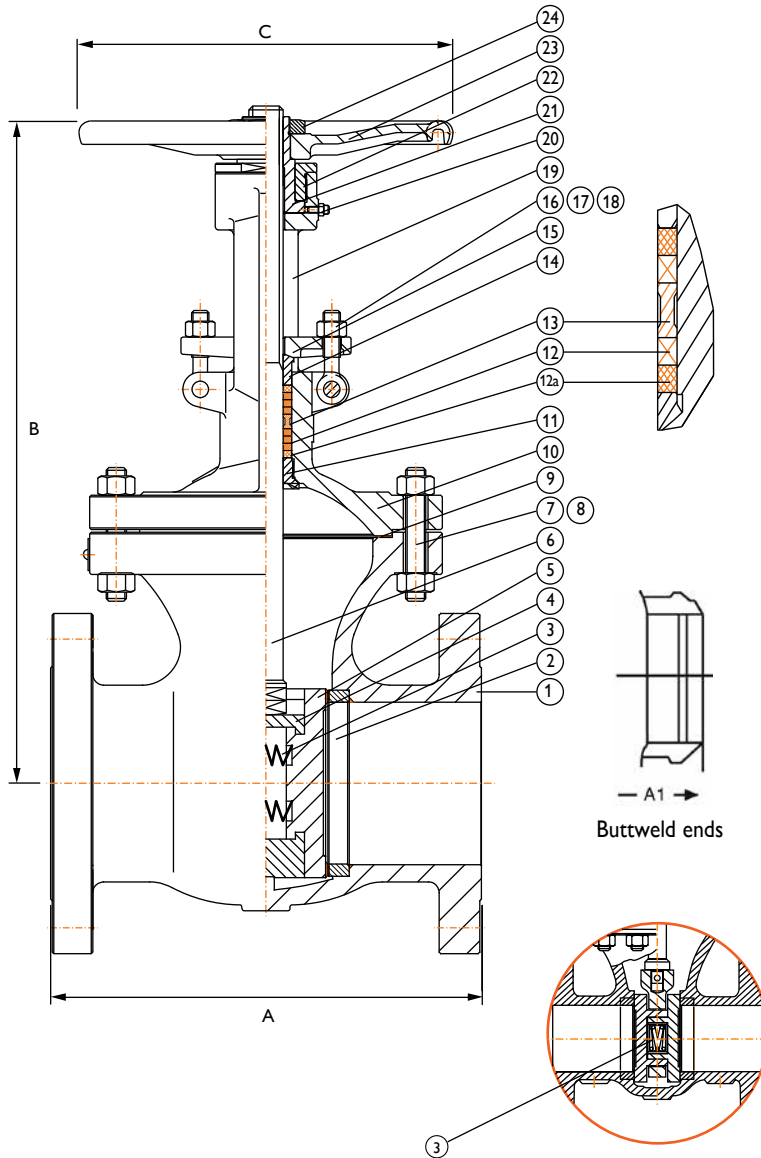

For installation in applications such as industrial, mining and mechanical services. Suitable for super-heated steam, H.T.H.W steam condensate and water.

This design consists of two discs, kept in contact with parallel body seats, using the line pressure and seating action to effect tight closure.

Temperature changes in the line are accommodated by the expanding disc & do not affect the action of the valve. When being opened or closed, the discs slide across the seat faces, dislodging any foreign matter. The valve operating stem is outside screw rising through the handwheel.

These valves are suitable for full bore steam use, where a low pressure drop across the valve is required.

Also suitable for water, oil, gas, etc.

STANDARD MATERIAL SPECIFICATIONS

Part	Material	
1	Body	ASTM A216 WCB
2	Seat	ASTM A105+ST#6
3	Spring	Inconel X-750
4	Disc Support Guide	ASTM A105
5	Disc	ASTM A105+ST#6
6	Stem (1)	ASTM A182 F6A
7	Bolt	ASTM A193 B7
8	Nut	ASTM A194 2H
9	Gasket Spiral Wound	SS316 + Graphite
10	Bonnet	ASTM A216 WCB
11	Back Seat	ASTM A274 410SS
12	Packing (2)	Flexible Graphite
12A	Packing (2)	Braided Graphite
13	Spacer Ring	ASTM A276 410SS
14	Gland	ASTM A276 410SS
15	Yoke Flange	ASTM A276 WCB
16	Nut	ASTM A194 2H
17	Bolt	ASTM A193 B7
18	Pin	AISI 1020
19	Yoke	ASTM A216 WCB
20	Grease Nipple	SS304
21	Stem Nut	ASTM A439 D2
22	Gland Nut	AISI 1035
23	Handwheel	Malleable Iron
24	Locking Nut	AISI 1035

(1) Stem smoothness Ra ≤ 0.80 μm

(2) Stuffing box smoothness Ra ≤ 3.2 μm (superior to API 600)

PRESSURE/TEMPERATURE WCB BODY

Class	Cat No.	Test Pressure to API 598 (PSIG)			Working Pressure	
		Shell (Hydro)	Seat (Hydro)	Seat (Air)	CWP WOG	Saturated Steam (at 260°C)*
150 (AS/BST D to F)	150-P316SXU-S	450	315	80	280	170
300 (AS/BST H to J)	300-P316SXU-S	1125	815	80	720	600
600	600-P316SXU-S	2225	1628	80	1440	1200
900	900-P316SXU-S	3350	2442	80	2190	1800

For superheated steam etc. consult chart.
WC6 chrome-moly available body for high temperature applications.

STANDARDS COMPLIANCE

Basic Design API 600, ANSI B16.34, BS 5157

Face to Face Dimension ANSI B16.10

End to End Dimension ANSI B16.10

Flanged Ends ANSI 16.5

B.W. Ends ANSI B16.25

Drilling to ANSI or BS/AS 2129 Table D to H or AS 4087 / AS 4331 / ISO 7005-1 PN 10 to 250

Pressure/Temperature Ratings to ANSI B16.5

O.S. & Y. Rising Stem Full Port, Expanded Parallel Slide Gate Valve, Double Disc, Pressure Seal or Bolted Bonnet, Welded-in or Threaded Seat Rings. Mechanically loaded seating for low and high pressure sealing.

Parallel slide dual loaded discs ensure superior shut off and allow by-pass/bleed fitment (double block and bleed requires soft seat inserts).

Pressure/temperature charts available on request.

PARALLEL SLIDE GATE VALVE

CAT P316S CLASS 150-900

TRIM MATERIAL CODES (TO API 600)

Seating Code	Body Seat Surface Part No. 3	Double Disc Surface Part No. 4	Stem Part No. 5	Back Seat (Stuffing Box) Part No. 10
X	F6	F6	F6	F6
U	Stellite	Stellite	F6	F6
XU	Stellite	F6	F6	F6
P*	F304	F304	F304	F304
R*	F316	F316	F316	F316
M*	Monel	Monel	Monel	Monel
N*	Alloy 20	Alloy 20	Alloy 20	Alloy 20
H*	Hastelloy B	Hastelloy B	Hastelloy B	Hastelloy B

Body Material Codes	
None	A216 WCB
0	Special
5	A217 C5
6	A217 WC6
7	A217 WC9
8	A351 CF8
8M	A351 CF8M

* Add XU modifier to end of model suffix if stellite seat, if stellite seat & disc add U modifier to end.

OVERALL DIMENSIONS (MM) & WEIGHT (KG)

VALVE SIZE (NPS)		inch	2	2-1/2	3	4	5	6	8	10	12	14	16	18	20	24
		mm	50	65	80	100	125	150	200	250	300	350	400	450	500	600
CLASS 150 (Table D to F)	D	mm	51	64	76	102	125	152	203	254	305	337	387	438	489	591
	A	mm	178	190	203	229	254	267	292	330	356	381	406	432	457	508
	B (Open)	mm	409	472	490	612	720	806	990	1186	1415	1583	1771	1955	2210	2698
	C	mm	200	200	250	250	350	350	350	450	500	560	640	720	800	900
	Weight (kg)	RF	20	25	38	55	75	85	134	198	320	400	524	690	900	1350
CLASS 300 (Table F to H)	D	mm	51	64	76	102	125	152	203	254	305	337	387	438	489	591
	A-A¹	mm	216	241	283	305	354	403	419	457	502	760	838	914	991	1143
	B (Open)	mm	428	477	543	650	720	850	1037	1276	1438	1585	1960	2155	2350	2720
	C	mm	200	250	250	300	300	350	450	500	560	640	720	800	900	1118
	Weight (kg)	RF	25	44	50	74	124	137	217	337	580	715	1050	1235	1655	2320
CLASS 600	D	mm	51	64	76	102	125	152	203	254	305	337	387	438	489	-
	A-A¹	mm	292	330	356	432	508	559	660	787	838	889	991	1092	1192	-
	B (Open)	mm	474	553	593	654	857	970	1122	1330	1519	1716	2110	2400	2461	-
	C	mm	250	250	300	350	400	500	560	720	720	720	900	1000	1000	-
	Weight (kg)	RF	50	60	85	135	260	345	515	845	1120	1360	1910	2335	2700	-
CLASS 900	D	mm	51	60	76	102	120	152	203	254	305	324	375	438	-	-
	A-A¹	mm	372	419	384	460	559	613	740	841	968	1039	1140	1219	-	-
	B (Open)	mm	590	702	740	870	1051	1078	1318	1581	1867	2004	2178	2526	-	-
	C	mm	250	300	300	350	450	560	640	800	800	900	900	900	-	-
	Weight (kg)	RF	110	140	150	220	355	460	800	1050	1600	2220	3000	3870	-	-

Note: 15mm to 40mm NB 150 ~ 2500 Class also available refer to individual drawings.



PARALLEL SLIDE GATE VALVE (EXPANDING)

CAT P316K CLASS 150-1500

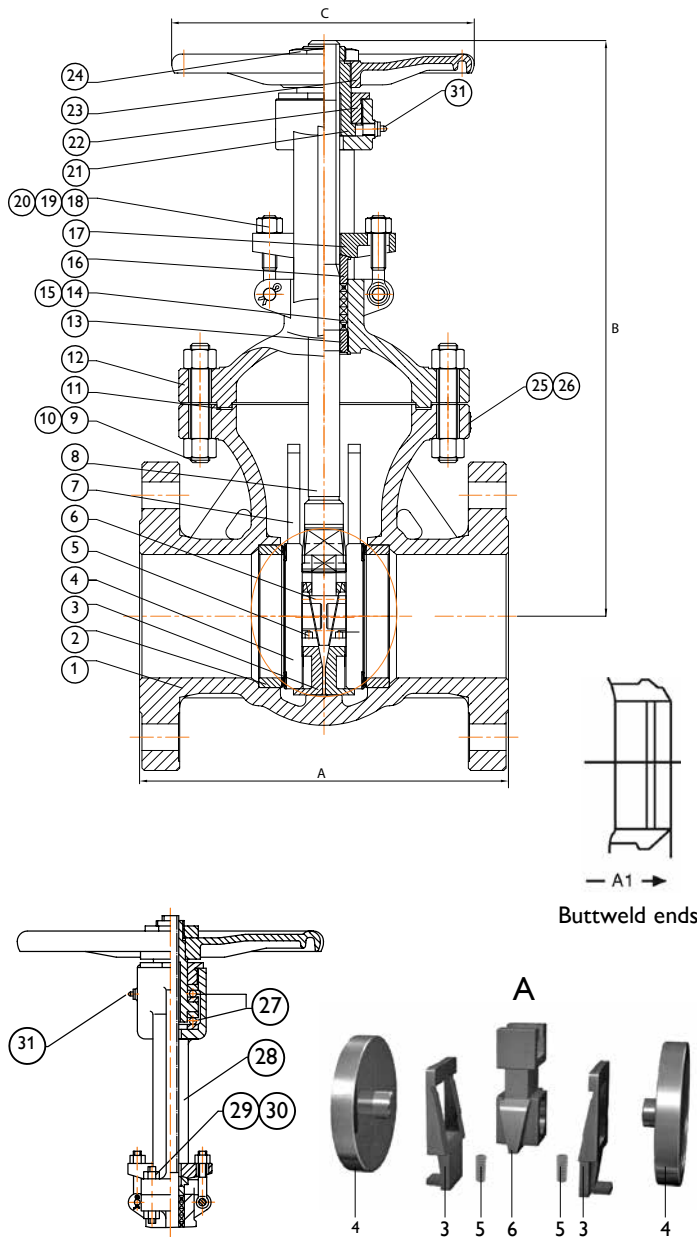

FEATURES

Expanding style parallel slide gate valve suitable for super-heated steam, H.T.H.W steam condensate and water.

Temperature changes in the line are accommodated by the expanding disc and do not affect the action of the valve. When being opened or closed, the discs slide across the seat faces, dislodging any foreign matter. These valves are suitable for full bore steam use, where a low pressure drop across the valve is required.

Also suitable for water, oil, gas, etc.

O.S. & Y. Rising Stem Full Port, Expanded Parallel Slide Gate Valve, Double Disc, Pressure Seal or Bolted Bonnet, Welded-in or Threaded Seat Rings. Mechanically loaded seating for low and high pressure sealing.

Parallel slide dual loaded discs ensure superior shut off and allow by-pass/bleed fitment (double block and bleed requires soft seat inserts).

Pressure/temperature charts available on request.

STANDARD MATERIAL SPECIFICATIONS

Part	Material	
1	Body	ASTM A217 WCB
2	Seat Ring	ASTM A105+STL.6
3	Wedge Blocks	ASTM A743 CA40
4	Discs	ASTM A105+STL.12
5	Springs	Inconel X-750
6	Disc Yoke	ASTM A743 C40
7	Guides	C.S.
8	Stem	ASTM A182 F6A
9	Studs	ASTM A193 B7
10	Nuts	ASTM A194 2H
11	Gasket	304SS+GRAPHITE
12	Bonnet	ASTM A216 WCB
13	Back Seat	ASTM A276 410
14	Packing	FLEXIBLE GRAPHITE
15	Packing	316+BRAIDED GRAPHITE
16	Gland	ASTM A276 410
17	Gland Flange	ASTM A217 WCB
18	Pins	AISI 1035
19	Eyebolts	ASTM A193 B7
20	Nuts	ASTM A194 2H
21	Stem Nut	ALUMINIUM BRONZE
22	Retaining Nut	AISI 1035
23	Handwheel	MALLEABLE IRON
24	Nuts	AISI 1035
25	Nameplate	316SS
26	Rivets	316SS
27	Bearings	SUB-ASSEMBLY
28	Yoke	ASTM A216 WCB
29	Studs	ASTM A193 B7
30	Nuts	ASTM A194 2H
31	Grease Nipple	BRASS

PRESSURE/TEMPERATURE WCB BODY

Class	Cat No.	Test Pressure to API 598 (PSIG)			Working Pressure	
		Shell (Hydro)	Seat (Hydro)	Seat (Air)	CWP WOG	Saturated Steam (at 260°C)*
150 (AS/BST D to F)	AP47XUKS	450	315	80	280	170
300 (AS/BST H to J)	AP33XUKS	1125	815	80	720	600
600	AP76XUKS	2225	1628	80	1440	1200
900	AP83XUKS	3350	2442	80	2190	1800
1500	AP83XUKS	5626	4078	80	3600	3000

For superheated steam etc. consult chart.
WC6 chrome-moly available body for high temperature applications.

* Also available with expanding wedge energiser (no spring) style - refer to drawing.

PARALLEL SLIDE GATE VALVE (EXPANDING)

CAT P316K CLASS 150-1500

SPECIFICATIONS

- Basic Design** API 600, ANSI B16.34
- Face to Face Dimension** ANSI B16.10
- End to End Dimension** ANSI B16.10
- Flanged Ends** ANSI 16.5
- B.W. Ends** ANSI B16.25
- Drilling to** ANSI or BS/AS 2129 Table D to H or AS 4087 / AS 4331.1 / ISO 7005-1 PN 10 to 250
- Pressure/Temperature ratings to ANSI B16.5

TRIM MATERIAL CODES (TO API 600)

Seating Code	Body Seat Surface Part No. 3	Double Disc Surface Part No. 4	Stem Part No. 5	Back Seat (Stuffing Box) Part No. 10
X	F6	F6	F6	F6
U	Stellite	Stellite	F6	F6
XU	Stellite	F6	F6	F6
P*	F304	F304	F304	F304
R*	F316	F316	F316	F316
M*	Monel	Monel	Monel	Monel
N*	Alloy 20	Alloy 20	Alloy 20	Alloy 20
H*	Hastelloy B	Hastelloy B	Hastelloy B	Hastelloy B

* Add XU modifier to end of model suffix if stellite seat, if stellite seat & disc add U modifier to end.

OVERALL DIMENSIONS (MM) & WEIGHT (KG)

VALVE SIZE (NPS)		inch	2	2-1/2	3	4	5	6	8	10	12	14	16	18	20	24
			50	65	80	100	125	150	200	250	300	350	400	450	500	600
CLASS 150 (Table D to F)	D	mm	51	64	76	102	125	152	203	254	305	337	387	438	489	591
	A	mm	178	190	203	229	254	267	292	330	356	381	406	432	457	508
	B (Open)	mm	409	472	490	612	720	806	990	1186	1415	1583	1771	1955	2210	2698
	C	mm	200	200	250	250	350	350	350	450	500	560	640	720	800	900
	Weight (kg)	RF	20	25	38	55	75	85	134	198	320	400	524	690	900	1350
CLASS 300 (Table F to H)	D	mm	51	64	76	102	125	152	203	254	305	337	387	438	489	591
	A-A1	mm	216	241	283	305	354	403	419	457	502	760	838	914	991	1143
	B (Open)	mm	428	477	543	650	720	850	1037	1276	1438	1585	1960	2155	2350	2720
	C	mm	200	250	250	300	300	350	450	500	560	640	720	800	900	1118
	Weight (kg)	RF	25	44	50	74	124	137	217	337	580	715	1050	1235	1655	2320
CLASS 600	D	mm	51	64	76	102	125	152	203	254	305	337	387	438	489	
	A-A1	mm	292	330	356	432	508	559	660	787	838	889	991	1092	1192	
	B (Open)	mm	474	553	593	654	857	970	1122	1330	1519	1716	2110	2400	2461	
	C	mm	250	250	300	350	400	500	560	720	720	720	900	1000	1000	
	Weight (kg)	RF	50	60	85	135	260	345	515	845	1120	1360	1910	2335	2700	
CLASS 900	D	mm	51	60	76	102	120	152	203	254	305	324	375	438		
	A-A1	mm	372	419	384	460	559	613	740	841	968	1039	1140	1219		
	B (Open)	mm	590	702	740	870	1051	1078	1318	1581	1867	2004	2178	2526		
	C	mm	250	300	300	350	450	560	640	800	800	900	900	900		
	Weight (kg)	RF	110	140	150	220	355	460	800	1050	1600	2220	3000	3870		

Note: 15mm to 40mm NB 150 ~ 2500 Class also available refer to individual drawings.



Open

Closed

PARALLEL SLIDE GATE VALVE

PARALLEL SLIDE GATE VALVE

CAT AP76SXXXXXXXXXX-P~AP25SXXXXXXXXXX-P - PRESSURE SEAL BONNET 600~2500 CLASS

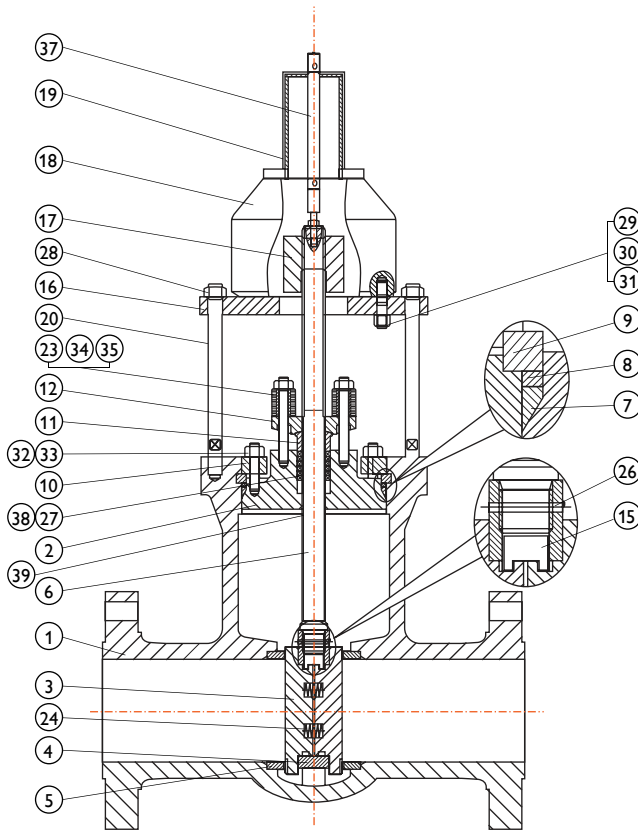

Pressure Seal (Pillar & Bridge Bonnet Style shown.)

MATERIALS LIST

Part Name	Carbon Steel to ASTM			Alloy Steel to ASTM			Stainless Steel to ASTM		
1 Body	A216 WCB	A352 LCB	A352 LCC	A217 WC6	A217 C5	A105	A351 CF8	A351 CF8M	A890 4A
2 Bonnet	A105	A350 LF2	A350 LF2	A105	A105	A182 F316	A182 F304	A182 F316	A182 F51
3 Gate*	A182 F316	A182 F316	A182 F316	A182 F316	A182 F316	A182 F316	A182 F316	A182 F316	A182 F51
4 Gate Retainer	A182 F316	A182 F316	A182 F316	A182 F316	A182 F316	A182 F316	A182 F316	A182 F316	A182 F51
5 Seat*	A182 F316	A182 F316	A182 F316	A182 F316	A182 F316	A182 F316	A182 F316	A182 F316	A182 F51
6 Stem	A564 S17400								
7 Silver Plated-Gasket	A182 F316	A182 F316	A182 F316	A182 F316	A182 F316	A182 F316	A182 F316	A182 F316	A182 F51
8 Thrust Ring	A182 F316	A182 F316	A182 F316	A182 F316	A182 F316	A182 F316	A182 F316	A182 F316	A182 F51
9 Pressure Collar	A105 +ENP	A350 LF2 +ENP	A350 LF2 +ENP	A105 +ENP	A105 +ENP	A105 +ENP	A182 F304	A182 F316	A182 F51
10 Pressure Plate	A105 +ENP	A350 LF2 +ENP	A350 LF2 +ENP	A105 +ENP	A105 +ENP	A105 +ENP	A182 F304	A182 F316	A182 F51
11 Gland	A182 F316	A182 F316	A182 F316	A182 F316	A182 F316	A182 F316	A182 F304	A182 F316	A182 F51
12 Gland Flange	A216 WCB	A352 LCB	A352 LCC	A217 WC6	A217 C5	A217 C12	A351 CF8	A351 CF8M	A890 4A
15 Stop Plate	A182 F316	A182 F316	A182 F316	A182 F316	A182 F316	A182 F316	A182 F316	A182 F316	A182 F51
16 Gland Adaptor Plate	A105	A350 LF2	A350 LF2	A105	A105	A105	A182 F304	A182 F316	A182 F51
17 Stem Nut	B150 C61900								
18 Gear	Steel								
19 Dust Proof Cover	Steel								
20 Yoke	Steel								
23 Belleville Spring	Steel +ZP/Inconel								
24 Spring	Steel								
26 Pin	A182 F316	A182 F316	A182 F316	A182 F316	A182 F316	A182 F316	A182 F316	A182 F316	A182 F51
27 Packing	Graphite								
28 Nut	A194 2H	A194 7	A194 7	A194 4	A194 4	A193 B16	A194 8	A194 8M	A194 8MLCuNa
29 Bolt	A193 B7	A320 L7	A320 L7	A193 B16	A193 B16	A194 4	193 B8	193 B8M	A193 B8MLCuN
30 Nut	A194 2H	A194 7	A194 7	A194 4	A194 4	A193 B16	A194 8	A194 8M	A194 8MLCuNa
31 Spring Washer	Steel								
32 Bolt	A193 B7	A320 L7	A320 L7	A193 B16	A193 B16	A194 4	A193 B8	A193 B8M	A193 B8MLCuN
33 Nut	A194 2H	A194 7	A194 7	A194 4	A194 4	A193 B16	A194 8	A194 8M	A194 8MLCuNa
34 Bolt	A193 B7	A320 L7	A320 L7	A193 B16	A193 B16	A194 4	A193 B8	A193 B8M	A193 B8MLCuN
35 Nut	A194 2H	A194 7	A194 7	A194 4	A194 4	A194 4	A194 8	A194 8M	A194 8MLCuNa
37 Stem Indicator	Steel								
38 Packing Ring	B150 C61900								
39 Backseat	Hard Face	Hard Face	Hard Face	Hard Face	Hard Face	Hard Face	Hard Face	Hard Face	Hard Face

* +Stellite where specified, Inconel & Monel option also available.

PARALLEL SLIDE GATE VALVE

PARALLEL SLIDE GATE VALVE

CAT P316SF-WF CLASS 150-2500 (15~50NB)

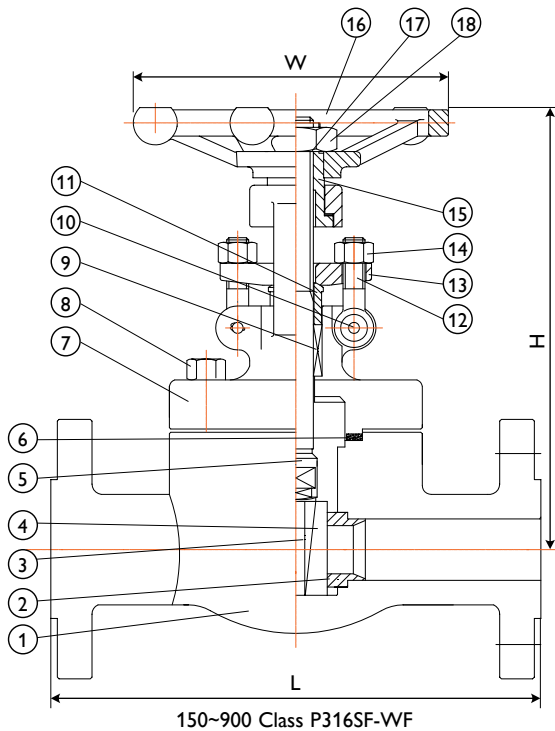

150~900 Class P316SF-WF

Wedge Spreader Rocker Die

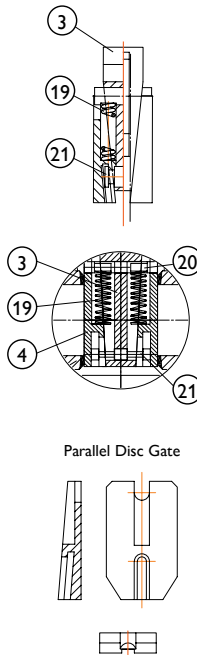
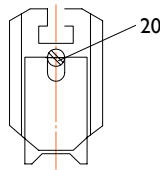
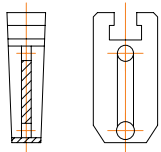

For installation in applications such as industrial, mining & mechanical services. Suitable for super-heated steam, H.T.H.W steam condensate & water.

This design consists of two discs, kept in contact with parallel body seats, using the line pressure and sprung seating action to effect tight closure.

Temperature changes in the line are accommodated by the expanding disc & do not affect the action of the valve. When being opened or closed, the discs slide across the seat faces, dislodging any foreign matter. The valve operating stem is outside screw rising through the handwheel.

These valves are suitable for steam use, where a low pressure drop across the valve is required. Also suitable for water, oil, gas, etc.

STANDARD MATERIALS 316SF-WF

No.	Part	Material
1	Body	A105N
2	Seat	SS410+ST#6
3	Spreader	SS420
4	Parallel Disc	A182 F6+ST#6
5	Stem	A182 F6
6	Gasket	SS304+Graphite
7	Bonnet	A105N
8	Bolt	A193 B7
9	Packing	Graphite
10	Pin	SS410
11	Gland	SS410
12	Gland Eyebolt	A193 B7
13	Gland Flange	A105N
14	Nut	A193 B7
15	Stem Nut	SS410
16	Handwheel	Steel
17	Washer	A3+ZP
18	Nut	A194 2H
19	Springs	Inconel X750
20	Location Pin	A182 F6
21	Connection Pin	A182 F6

Contact us for detailed drawing.

PRESSURE/TEMPERATURE A105N BODY

Class	Cat No.	Test Pressure to API 598 (PSIG)			Working Pressure	
		Shell (Hydro)	Seat (Hydro)	Seat (Air)	CWP WOG	Saturated Steam (at 260°C)*
150 (AS/BST D to F)	150-P316SFXU-S	450	315	80	280	170
300 (AS/BST H to J)	300-P316SFXU-S	1125	815	80	720	600
600	600-P316SFXU-S	2225	1628	80	1440	1200
900	900-P316SFXU-S	3350	2442	80	2190	1800
1500	1500-P136SFXU-S	5626	4078	80	3600	3000

For superheated steam etc. consult chart.
F11, F22, F5 chrome-moly available body for high temperature applications.

TRIM MATERIAL CODES

Seating Code	Body Seat Surface Part No. 3	Double Disc Surface Part No. 4	Stem Part No. 5	Back Seat (Stuffing Box) Part No. 10	Body Material Codes	
					None	A105N
X	F6	F6	F6	F6	0	Special
U	Stellite	Stellite	F6	F6	5	A182 F5/F5a
XU	Stellite	F6	F6	F6	6	A182 F11
P*	F304	F304	F304	F304	8	A182 F304/304L
R*	F316	F316	F316	F316	8M	A182 F316/316L
M*	Monel	Monel	Monel	Monel	9	A182 F22
N*	Alloy 20	Alloy 20	Alloy 20	Alloy 20		
H*	Hastelloy B	Hastelloy B	Hastelloy B	Hastelloy B		

* Add XU modifier to end of model suffix if stellite seat, if stellite seat & disc add U modifier to end.

STANDARDS COMPLIANCE

Basic Design API 602/ANSI B16.34, BS 5157
Face to Face Dimension ANSI B16.10
End to End Dimension ANSI B16.10
Flanged Ends ANSI 16.5
B.W. Ends ANSI B16.25
S.W. Ends ANSI B16.11
Drilling to ANSI or BS/AS 2129 Table D to H or AS 4087 / AS 4331 / ISO 7005-1 PN 10 to 250
Pressure/Temperature Ratings to ANSI B16.5

O.S. & Y. Rising Stem Full Port, Expanded Parallel Slide Gate Valve, Double Disc, Pressure Seal or Bolted Bonnet, Welded-in or Threaded Seat Rings. Mechanically loaded seating for low and high pressure sealing.

Parallel slide dual loaded discs ensure superior shut off and allow by-pass/bleed fitment (double block and bleed requires soft seat inserts).

Pressure/temperature charts available on request.

Available in A105N, F22, F11, F5, 316, 304 etc.

PARALLEL SLIDE GATE VALVE

CAT P316SF-VV/WFL CLASS 150-2500 (15~50NB)

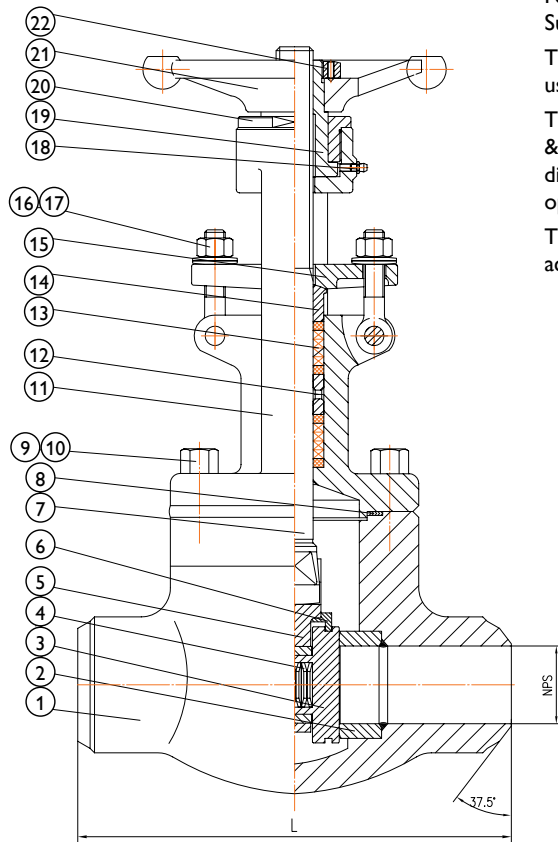

150~1500 Class P316SF-VV/WFL (32NB~50NB)

For installation in applications such as industrial, mining and mechanical services. Suitable for super-heated steam, H.T.H.W steam condensate and water.

This design consists of two discs, kept in contact with parallel body seats, using the line pressure and sprung seating action to effect tight closure.

Temperature changes in the line are accommodated by the expanding disc & do not affect the action of the valve. When being opened or closed, the discs slide across the seat faces, dislodging any foreign matter. The valve operating stem is outside screw rising through the handwheel.

These valves are suitable for full bore steam use, where a low pressure drop across the valve is required. Also suitable for water, oil, gas, etc.

STANDARD MATERIAL 316SF-VV 150 ~ 900CL

Part	Material	
1	Body	ASTM A105N
2	Seat	ASTM A105+STL
3	Disc	ASTM A105+STL
4	Spring	Inconel X-750
5	Gate Frame	ASTM A105
6	Skirt	A240 410
7	Stem	A182 F6a
8	Bonnet Gasket	Graphite+304
9	Bolt	A193 B7
10	Nut	A194 2H
11	Bonnet	ASTM A105
12	Lantern Ring	A182 F6a
13	Packing	Graphite
14	Packing Bushing	A182 F6a
15	Packing Gland	ASTM A105
16	Gland Eyebolt	A193 B7
17	Nut	A194 2H
18	Oil Cup	Cu
19	Stem Nut	ZQAL9-4
20	Bearing Cover	AISI 1035
21	Hand Wheel	A216 WCB
22	Gland Nut	AISI 1035

Contact us for detailed drawing.

PRESSURE/TEMPERATURE A105N BODY

Class	Cat No.	Test Pressure to API 598 (PSIG)			Working Pressure	
		Shell (Hydro)	Seat (Hydro)	Seat (Air)	CWP WOG	Saturated Steam (at 260°C)*
150 (AS/BST D to F)	150-P316SF XU-S	450	315	80	280	170
300 (AS/BST H to J)	300-P316SF XU-S	1125	815	80	720	600
600	600-P316SF XU-S	2225	1628	80	1440	1200
900	900-P316SF XU-S	3350	2442	80	2190	1800
1500	1500-P316SF XU-S	5626	4078	80	3600	3000

For superheated steam etc. consult chart.

F11, F22, F5 chrome-moly available body for high temperature applications.

STANDARDS COMPLIANCE

Basic Design API 600, ANSI B16.34, BS 5157

Face to Face Dimension ANSI B16.10

End to End Dimension ANSI B16.10

Flanged Ends ANSI 16.5

B.W. Ends ANSI B16.25

S.W. Ends ANSI B16.11

Drilling to ANSI or BS/AS 2129 Table D to H or AS 4087 / AS 4331 / ISO 7005-1 PN 10 to 250

Pressure/Temperature Ratings to ANSI B16.5

Bolted Bonnet O.S. & Y. Rising Stem Full Port, Expanded Parallel Slide Gate Valve, Double Disc, Pressure Seal or Bolted Bonnet, Welded-in or Threaded Seat Rings. Mechanically loaded seating for low and high pressure sealing.

Parallel slide dual loaded discs ensure superior shut off and allow by-pass/bleed fitment (double block and bleed requires soft seat inserts).

Pressure/temperature charts available on request.

Available in A105N, F22, F11, F5, 316, 304 etc.

(Pillar & Post style bonnet also available.)

TRIM MATERIAL CODES

Seating Code	Body Seat Surface Part No. 3	Double Disc Surface Part No. 4	Stem Part No. 5	Back Seat (Stuffing Box) Part No. 10	Body Material Codes	
					None	A105N
X	F6	F6	F6	F6	0	Special
U	Stellite	Stellite	F6	F6	5	A182 F5/F5a
XU	Stellite	F6	F6	F6	6	A182 F11
P*	F304	F304	F304	F304	8	A182 F304/304L
R*	F316	F316	F316	F316	8M	A182 F316/316L
M*	Monel	Monel	Monel	Monel	9	A182 F22
N*	Alloy 20	Alloy 20	Alloy 20	Alloy 20		
H*	Hastelloy B	Hastelloy B	Hastelloy B	Hastelloy B		

* Add XU modifier to end of model suffix if stellite seat, if stellite seat & disc add U modifier to end.

PARALLEL SLIDE BLOWDOWN VALVE

PARALLEL SLIDE BLOWDOWN VALVE RACK & PINION - QUICK ACTING

CAT 710VW CLASS 150-2500 (15~50NB)



Key Operated Version (Integral Flanges)

Quick acting - Uniflo style lever or key operated continuous boiler blow down valves (blow off) for installation in applications such as industrial, mining and mechanical services. Suitable for super-heated steam, H.T.H.W steam condensate and water.

This design consists of two discs, kept in contact with parallel body seats, using the line pressure & sprung seating action to effect tight closure.

Temperature changes in the line are accommodated by the expanding disc and do not affect the action of the valve. When being opened or closed, the discs slide across the seat faces, dislodging any foreign matter.

The valve operating stem is outside screw rising through the handwheel.

These valves are suitable for full bore steam use, where a low pressure drop across the valve is required. Also suitable for water, oil, gas, etc.

Also available in Globe style, quick acting.

PRESSURE/TEMPERATURE A105N BODY

Class	Cat No.	Test Pressure to API 598 (PSIG)			Working Pressure	
		Shell (Hydro)	Seat (Hydro)	Seat (Air)	CWP WOG	Saturated Steam (at 260°C)*
150 (AS/BST D to F)	150-710VWXU-S	450	315	80	280	170
300 (AS/BST H to J)	300-710VWXU-S	1125	815	80	720	600
600	600-710VWXU-S	2225	1628	80	1440	1200
900	900-710VWXU-S	3350	2442	80	2190	1800
1500	1500-710VWXU-S	5626	4078	80	3600	3000

For superheated steam etc. consult chart.

F11, F22, F5 chrome-moly available body for high temperature applications.

TRIM MATERIAL CODES

Seating Code	Body Seat Surface Part No. 3	Double Disc Surface Part No. 4	Stem Part No. 5	Back Seat (Stuffing Box) Part No. 10
X	F6	F6	F6	F6
U	Stellite	Stellite	F6	F6
XU	Stellite	F6	F6	F6
P*	F304	F304	F304	F304
R*	F316	F316	F316	F316
M*	Monel	Monel	Monel	Monel
N*	Alloy 20	Alloy 20	Alloy 20	Alloy 20
H*	Hastelloy B	Hastelloy B	Hastelloy B	Hastelloy B

* Add XU modifier to end of model suffix if stellite seat, if stellite seat & disc add U modifier to end.

STANDARDS COMPLIANCE

Basic Design ANSI B16.34, BS 5157

Face to Face Dimension ANSI B16.10

End to End Dimension ANSI B16.10

Flanged Ends ANSI 16.5

B.W. Ends ANSI B16.25

S.W. Ends ANSI B16.11

Drilling to ANSI or BS/AS 2129 Table D to H or AS 4087 / AS 4331 / ISO 7005-1 PN 10 to 250

Pressure/Temperature Ratings to ANSI B16.5

O.S. & Y. Rising Stem Full Port, Expanded Parallel Slide Gate Valve, Double Disc, Bolted Bonnet, Integral Seal Rings - Metal to Metal. Mechanically loaded seating for low and high pressure sealing.

Parallel slide dual loaded discs ensure superior shut off and allow by-pass/bleed fitment (double block and bleed requires soft seat inserts).

Pressure/temperature charts available on request.

Available in A105N, F22, F11, F5, 316, 304 etc.

Body Material Codes	
None	A105N
0	Special
5	A182 F5/F5A
6	A182 F11
8	A182 F304/304L
8M	A182 F316/316L
9	A182 F22

GATE VALVE GEOTHERMAL TRIM

CAT AP33XXXXXXXXXX-XGE CLASS 300

RIISING STEM, NON RISING HANDWHEEL OS&Y OUTSIDE SCREW & YOKE FULL PORT DESIGN (SPECIAL LARGE BORE ALSO AVAILABLE) FLEXIBLE WEDGE

Description	Material	Specs.
Body	Carbon Steel	A216 Gr. WCB
Bonnet	Carbon Steel	A216 Gr. WCB
Disc	Carbon Steel + HF	A216 Gr.WCB + Stellite #12
Stem	Stainless Steel	17-4PH
Hand Wheel	Ductile Iron	A536 Gr. 65-45-12
Seat	Carbon Steel + HF	A105 + Stellite #6
Back Seat Ring	Integral	Stellite #6
Yoke Sleeve	Ductile Iron or Bronze	A439 Gr. D2C or B62
Sleeve Gland	Carbon Steel	A216 Gr. WCB
Gland Flange	Carbon Steel	A105
Gland Ring	Stainless Steel	A276 Gr. 420
Wheel Nut	Carbon Steel	A105
Bonnet Bolt	Carbon Steel	A193 Gr. B7/B7M
Bonnet Nut	Carbon Steel	A194 Gr. 2H/2HM
Gland Bolt	Carbon Steel	A193 Gr. B7
Gland Nut	Carbon Steel	A194 Gr. 2H
Gland Bolt Pin	Carbon Steel	A108 Gr. 1020
Bearing	-	Thrust Ball
Grease Nipple	Carbon Steel	A307 Gr. B
Set Screw	Carbon Steel	A307 Gr. B
Name Plate	Stainless Steel	304/AL
Packing	Asbestos Free	Reinforced Graphite*
Gasket	Spiral Wound	316 Graphite filled

* -180°C to 450°C Chesterton #1600 packing

Standards	
Face to Face/End to End	ANSI B16.10
Flange Dimensions	ANSI B16.5
Basic Design	API 600/ISO 10434
Testing	API 598

DIMENSIONS (MM)

Size (in)	1-1/2"	2"	2-1/2"	3"	4"	5"	6"	8"	10"	12"	14"	16"
A. Face to Face RF	190	216	241	283	305	381	403	419	457	502	762	838
A. Face to Face RTJ	203	232	257	298	321	397	419	435	473	518	788	854
A. End to End BW	190	216	241	283	305	381	403	419	457	502	762	838
B. Valve Open	365	429	457	527	619	800	829	1025	1213	1473	1289	1784
C. Hand Wheel Dia	229	229	229	254	305	350	406	457	508	559	559	559
Weight (Kg) RF/RTJ	20	24	44	50	74	106	137	217	337	580	715	1050
Weight (Kg) BW	16	20	35	37	54	100	110	174	285	495	615	940

DIMENSIONS (MM)

Size (in)	18"	20"	24"
A. Face to Face RF	914	991	1143
A. Face to Face RTJ	930	1010	1165
A. End to End BW	914	991	1143
B. Valve Open	1965	2194	2578
C. Hand Wheel Dia	610	660	660
Weight (Kg) RF/RTJ	1235	1655	2320
Weight (Kg) BW	1090	1500	2100

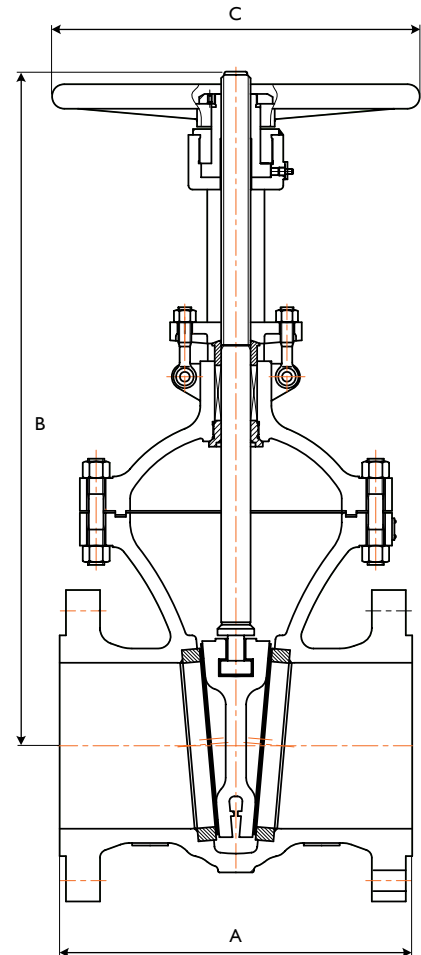

STOP CHECK GLOBE VALVE SCREW DOWN NON RETURN

CAT AP143XXXXXXXXXX-D/AP151XXXXXXXXXX-D/AP171XXXXXXXXXX-D CLASS 150-600

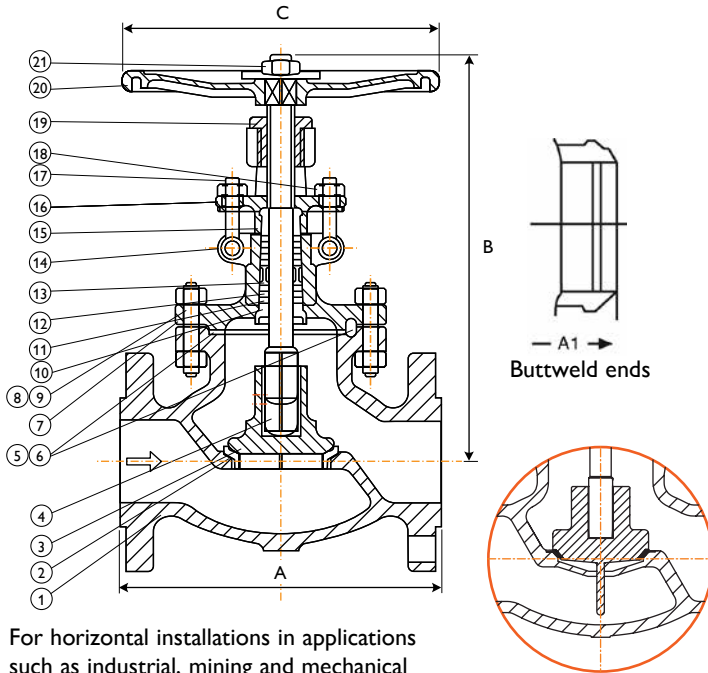

For horizontal installations in applications such as industrial, mining and mechanical services, suitable for H.T.H.W., steam, condensate and water.

WORKING PRESSURE

P143XXXXXXXXXX XU-D 150 CLASS
280 PSI CWP (WOG)
170 PSI Saturated Steam (at 260°C)

P151XXXXXXXXXX XU-D 300 CLASS
720 PSI CWP (WOG)
600 PSI Saturated Steam (at 260°C)

P171XXXXXXXXXX XU-D 600 CLASS
1440 PSI CWP (WOG)
1100 psi at 260°C, 825 psi at 400°C.

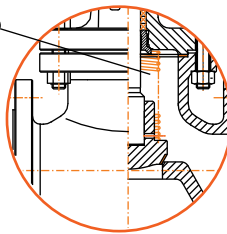

Optional Spring Assisted (SDNR)

STANDARD MATERIAL SPECIFICATIONS

Part Name	Materials	
1	Body	ASTM A216 Gr. WCB
2	Seat Ring	ASTM A105 with HF overlay
3	Disc	ASTM A105 with F6 overlay
4	Stem	ASTM A182 Gr. F6
5	Gasket	Spiral Wound 316/GRP
6	Gasket	Ring Joint CAD Plated
7	Bonnet	ASTM A216 Gr. WCB (or WC6)
8	Bonnet Bolt	ASTM A193 Gr. B7
9	Bonnet Nut	ASTM A194 Gr. 2H
10	Back Seat Bushing	ASTM A182 Gr. F6
11	Stem Packing	Braided graphite (top & Bottom)
12	Stem Packing	Flexible graphite
13*	Lantern Ring	ASTM A182 Gr. F6
14	Pin	ASTM A182 Gr. F6
15	Gland	ASTM A182 Gr. F6
16	Gland Flange	ASTM A216 Gr. WCB
17	Gland Bolt	ASTM A193 Gr. B7
18	Gland Nut	ASTM A194 Gr. 2H
19	Yoke Bush	Gr. D2C or Bronze B62
20†	Handwheel	A536/A197
21	Wheel Nut	ASTM A105
22*	Torque Arm	ASTM A105
23	Guided Spring	InconelX750 - Optional

* Fitted on larger sizes & higher classes.
† Gearboxes on larger sizes.

FEATURES

Screw-Down Non-Return Globe Valve
Guided loose disc for combination check & stop.
Bolted Bonnet, O.S. & Y., Swivel Disc.

STANDARDS COMPLIANCE

Basic Design API 600/BS 1873 & ANSI B16.34
Face to Face Dimension ANSI B16.10
End to End Dimension ANSI B16.10
Flanged Ends ANSI 16.5
B.W. Ends ANSI B16.25
Drilling to ANSI or BS/AS 2129 Table D to H
or AS 4087/AS 4331.1/ISO 7005-1/EN 1092-1/PN10 to PN100

OVERALL DIMENSIONS (MM & IN) & WEIGHT (KG)

VALVE SIZE (NPS)		inch	2	2-1/2	3	4	5	6	8	10	12	
		mm	50	65	80	100	125	150	200	250	300	
CLASS 150* (Table D TO F)	A-A ¹ (RF-BW)	inch	8	8-1/2	9-1/2	11-1/2	14	16	19-1/2	24-1/2	27-1/2	
		mm	203	216	241	292	356	406	495	622	698.5	
	B (Open)	inch	13-3/4	14-7/8	16	17-7/8	22-3/8	22-1/2	24-7/8	29-1/8	39-3/8	
		mm	349	378	407	454	569	573	632	740	1000	
	C	inch	8	10	10	12	15	16	18	20	20	
		mm	200	250	250	300	390	400	450	500	500	
	Weight (kg)	inch	22	31	37	58	103	111	179	240	410	
		mm	19	25	26	50	95	101	159	215	370	
	CLASS 300* (Table F TO H)	A-A ¹ (RF-BW)	inch	10-1/2	11-1/2	12-1/2	14	15-3/4	17-1/2	22	24-1/2	28
			mm	267	292	318	356	400	444.5	559	622	711
B (Open)		inch	14-1/4	15-1/2	16-7/8	19	26-3/8	26-5/8	30-1/2	40-7/8	54-1/8	
		mm	362	394	429	482	669	676	774	1040	1375	
C		inch	8	10	12	14	16.9	18	20	20	20	
		mm	200	250	300	350	430	450	500	500	500	
Weight (kg)		inch	28	47	54	76	150	162	270	340	550	
		mm	22	40	43	61	130	136	232	280	520	
CLASS 600*		A-A ¹ (RF-BW)	inch	11-1/2	13	14	17	-	22	26	31	33
			mm	292	330	356	432	-	559	660	787	838
	A (RTJ)	inch	11-5/8	13-1/8	14-1/8	17-1/8	-	22-1/8	26-1/8	31-1/8	33-1/8	
		mm	295	333	359	435	-	562	664	791	841	
	B (Open)	inch	19-1/2	21-1/8	23-1/4	28-1/8	-	38-5/8	44-3/4	50-3/32	58-2/3	
		mm	495	537	590	714	-	981	1136	1276	1490	
	C	inch	10	12	14	16	-	22	24	24	26-7/8	
		mm	250	300	350	400	-	550	600	600	680	
	Weight (kg)	inch	51	62	85	143	-	340	520	720	950	
		mm	42	51	72	120	-	284	465	580	830	

*Available in undrilled to accommodate AS/BS or PN/JIS table drilling. ANSI flanges can also be machined to AS/BS table thickness to allow face to face dimension alteration. 1/2" to 1-1/2" see page 44 of APV Cast, Gate, Globe, Check Catalogue (Full Version).

RIGHT ANGLE GLOBE VALVE

RIGHT ANGLE GLOBE VALVE

CAT AP143XXXXXX-R/AP151XXXXXX-R/AP171XXXXXX-R
CLASS 150-600

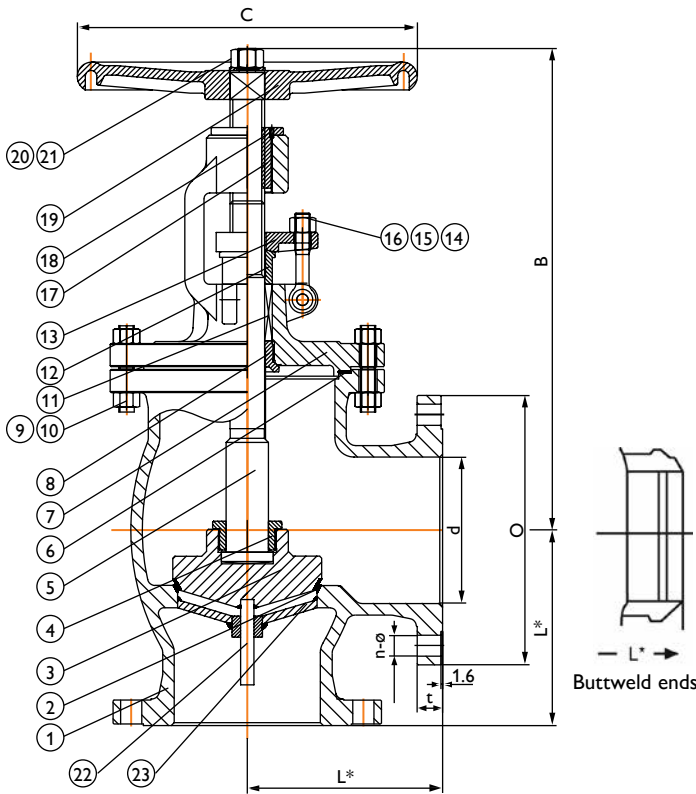

For installations in application such as industrial, mining & mechanical services. Suitable for super-heated steam, H.T.H.W, steam, condensate and water. Stem is guided for smooth operation. Also available in Bronze, Iron, chrome-moly etc.

Customer must specify flow direction (Horizontal or Vertical)

Globe Valve (combination globe & check valve), Bolted Bonnet, O.S. & Y., Swivel Disc (guided loose disc for combination check & stop). Can also be supplied as standard globe stop valve. Drilling to ANSI, AS 2129 Table D to H or AS 4331.1 /ISO 7005-1 / AS 4087 PN10 to 100.

STANDARD MATERIAL SPECIFICATIONS

No	Part	Material
1	Body	ASTM A216 WCB
2	Seat	ASTM A105+STL#6 overlay
3	Disc	ASTM A105+13CR
4	Disc Cover	ASTM A276 410
5	Stem	ASTM A182 F6A
6	Gasket	SS316+Graphite
7	Bonnet	ASTM A216 WCB
8	Back Seat	ASTM A276 410
9	Bolt	ASTM A193 B7
10	Nut	ASTM A194 2H
11	Packing	Graphite
12	Gland	ASTM A216 410
13	Gland Flange	ASTM A216 WCB
14	Bolt	ASTM A193 B7
15	Nut	ASTM A194 2H
16	Pin	AISI 1035
17	Stem Nut	Copper Alloy
18	Set Screw	ASTM A193 B7
19	Handwheel	Malleable Iron
20	Washer	A3+ZP
21	Locking Nut	ASTM A194 2H
22	Guide Pin	AISI 1035
23	Guide Cage	AISI 1035

Note: Other body & trim materials are available upon request, such as bronze.

OVERALL DIMENSIONS (MM) & WEIGHT (KG)

VALVE SIZE (NPS)		inch	2	2-1/2	3	4	5	6	8	10	12	
		mm	50	65	80	100	125	150	200	250	300	
CLASS 150 (Table D TO F)	L* (RF-BW)	mm	102/114	108/146	146/159	152/165	178	203/216	241/248	305/311	305/349	
	B (Open)	mm	373	390	420	500	550	565	670	770	880	
	C	mm	200	250	250	300	390	390	450	550	600	
	O	mm	152	178	191	229	254	279	343	406	483	
	Weight (kg)	RF		22	31	377	58	103	111	179	240	-
		BW		19	25	26	50	95	101	159	215	35
CLASS 300 (Table F TO H)	L* (RF-BW)	mm	133	127/146	140/159	146/178	178/191	222	267/279	311	349/355	
	B (Open)	mm	390	425	485	580	700	770	900	1020	700	
	C	mm	200	250	300	350	430	450	500	600	600	
	O	mm	165	191	210	254	279	318	381	445	520	
	Weight (kg)	RF		28	47	54	76	150	162	270	-	-
		BW		22	40	43	61	130	136	232	394	-
CLASS 600	L* (RF-BW)	mm	146	165	178	216	-	279	330	394	419	
	B (Open)	mm	423	498	575	750	-	1030	1290	1300	1504	
	C	mm	250	300	350	450	-	600	650	650	650	
	O	mm	165	191	210	273	-	356	419	510	560	
	Weight (kg)	RF		51	62	85	143	-	340	520	-	-
		BW		42	51	72	120	-	284	465	-	-

* Two patterns are available hence 2 dimensions have been shown. 15 to 40NB and 350 to 400NB also available, refer to drawing.

WORKING PRESSURE

P143XXXXXXR 150 CLASS

280 PSI CWP (WOG)
170 PSI Saturated Steam (at 260°C)

P151XXXXXXR 300 CLASS

720 PSI CWP (WOG)
600 PSI Saturated Steam (at 260°C)

For superheated steam consult pressure/temp chart

P171XXXXXXR 600 CLASS

1440 PSI CWP (WOG)

WC6 body is available for high temperature applications, consult P/T chart.

STANDARDS COMPLIANCE

Basic Design BS 1873/ANSI B16.34

Test API Standard 598

Flanged Ends ANSI B16.5 or BS/AS/PN

B.W. Ends ANSI B16.25

Face to Face Dimension BS 2820 or ANSI B16.10

Pressure/Temperature Ratings to ANSI B16.34.

PISTON CHECK VALVE

PISTON CHECK - LIFT TYPE

CAT SLCL CLASS 150-600

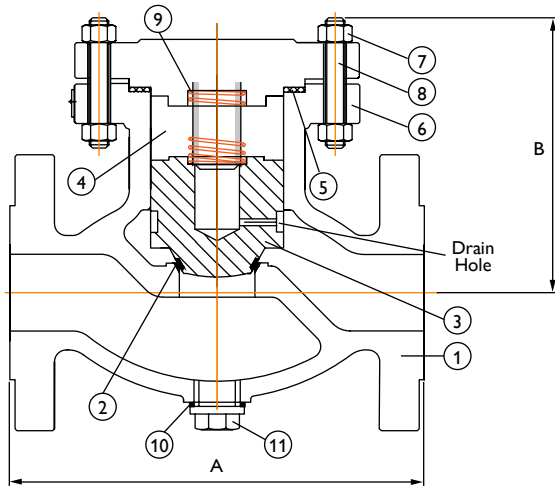

SLCL-Z
Spring Activated

(Guiding mechanism varies according to size class, refer to drawing)

WORKING PRESSURE

SLCLXU-Z 150 CLASS

280 PSI CWP (WOG)

170 PSI Saturated Steam (at 260°C)

SLCLXU-Z 300 CLASS

720 PSI CWP (WOG)

600 PSI Saturated Steam (at 260°C)

For superheated steam consult pressure/temp chart

SLCLXU-Z 600 CLASS

1440 PSI CWP (WOG)

1100 PSI at 260°C, 825 psi at 400°C.

Consult chart for other temperatures

WC6 body is available for high temperature applications

Non return Piston Check valve, lift type, bolted bonnet, guided disc. Flange drilling ANSI 150 to 600 and AS2129 table D to H and PN10 to 100.

For horizontal installations in applications such as industrial, mining and mechanical services. Suitable for super-heated steam, H.T.H.W., steam, condensate and water.

Guiding of stem assures smooth operation.

Other body materials like Bronze and WC6 also available.

STANDARD MATERIAL SPECIFICATIONS

Part	Material	
1	Body	ASTM A216 Gr. WCB
2	Seat Ring	ASTM A105 with HF overlay
3/4	Disc/Stem	ASTM A105 with F6 overlay
5	Gasket	Stainless Steel/Graphite
6	Bonnet/Guide	ASTM A216 Gr. WCB
7	Bonnet Nut	ASTM A194 Gr. 2H
8	Bonnet Bolt	ASTMA193 Gr. B7
9*1	Spring	Inconel X750
10	Gasket	Graphite
11*2	Drain Plug	A105N

*1 Spring Optional. *2 Drain Optional.

STANDARDS COMPLIANCE

Basic Design API 600/BS 1873 and ANSI B16.34

Face to Face Dimension ANSI B16.10

End to End Dimension ANSI B16.10

Flanged Ends ANSI 16.5

B.W. Ends ANSI B16.25

Drilling to ANSI or BS/AS 2129 Table D to H

and PN10 to 100

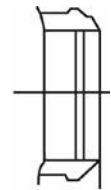

— A1 —
Buttweld ends

OVERALL DIMENSIONS (MM & INCHES) & WEIGHT (KG)

VALVE SIZE (NPS)		inch	2	2-1/2	3	4	5	6	8	10	12
		mm	50	65	80	100	125	150	200	250	300
CLASS 150 (Table D to F) (PN10~21)	A-A1 (RF-BW)	inch	8	8-1/2	9-1/2	11-1/2	14	16	19-1/2	24-1/2	27-1/2
		mm	203	216	241	292	356	406	495	622	698.5
	B	inch	6-7/8	7	7-1/2	8-5/8	9-1/4	12-3/4	15-1/8	17-5/8	21-1/4
		mm	175	178	191	219	235	324	384	448	540
	Weight (kg)	RF	20	24	35	55	84	96	160	245	345
		BW	14	17	26	37	52	80	133	213	294
CLASS 300 (Table F to H) (PN25~50)	A-A1 (RF-BW)	inch	10-1/2	11-1/2	12-1/2	14	15-3/4	17-1/2	21	24-1/2	28
		mm	267	292	318	356	400	444	533	622	711
	B	inch	7-3/4	8	8-3/4	10-7/8	11-5/8	13-1/4	16-1/4	18-1/4	22-1/8
		mm	197	203	222	276	295	337	413	464	562
	Weight (kg)	RF	35	37	60	82	110	155	268	380	495
		BW	32	35	50	65	70	128	230	270	460
CLASS 600 (PN50~100)	A-A1 (RF-BW)	inch	11-1/2	13	14	17	20	22	26	31	33
		mm	292	330	356	432	508	559	660	787	838
	B	inch	8-1/4	8-5/8	10-1/2	11-3/4	13-1/4	15	18-3/4	21-5/8	22-5/8
		mm	210	219	267	299	337	381	476	549	670
	Weight (kg)	RF	40	55	72	120	175	270	420	620	810
		BW	31	45	60	85	125	225	365	500	715

PISTON CHECK - LIFT TYPE

CAT SLCL-W CLASS 150-600

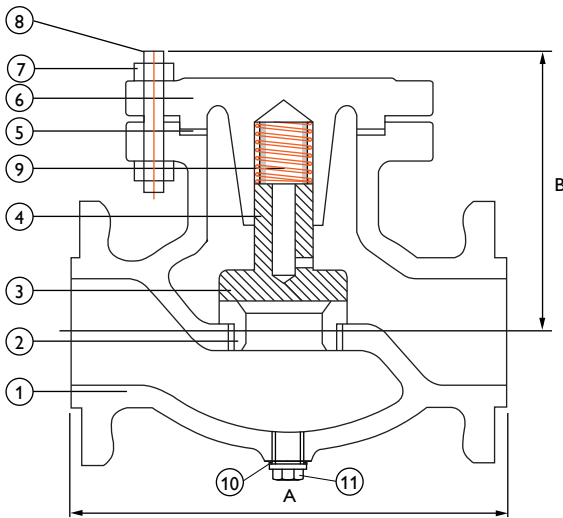

SLCL-W
Spring Activated

WORKING PRESSURE

SLCLXU-Z 150 CLASS

280 PSI CWP (WOG)
170 PSI Saturated Steam (at 260°C)

SLCLXU-Z 300 CLASS

720 PSI CWP (WOG)
600 PSI Saturated Steam (at 260°C)

For superheated steam consult pressure/temp chart

SLCLXU-Z 600 CLASS

1440 PSI CWP (WOG)
1100 PSI at 260°C, 825 psi at 400°C.

Consult chart for other temperatures

WC6 body is available for high temperature applications

Non return Piston Check valve, lift type, bolted bonnet, guided disc. Flange drilling ANSI 150 to 600 & BS/AS2129 table D to H, and PN10 to 100.

For horizontal installations in applications such as industrial, mining and mechanical services. Suitable for super-heated steam, H.T.H.W., steam, condensate and water.

Guiding of stem assures smooth operation.

Other body materials like Bronze and WC6 also available.



(S-Bend Type Body shown)

STANDARD MATERIAL SPECIFICATIONS

Part	Material	
1	Body/Guide	ASTM A216 Gr. WCB
2	Seat Ring	ASTM A105 with HF overlay
3/4	Disc/Stem	ASTM A105 with F6 overlay
5	Gasket	Stainless Steel/Graphite
6	Bonnet	ASTM A216 Gr. WCB
7	Bonnet Nut	ASTM A194 Gr. 2H
8	Bonnet Bolt	ASTM A193 Gr. B7
9*1	Spring	Inconel X750
10	Gasket	Graphite
11*2	Drain Plug	A105N

*1 Spring Optional. *2 Drain Optional.

STANDARDS COMPLIANCE

Basic Design API 600/BS 1873 and ANSI B16.34

Face to Face Dimension ANSI B16.10

End to End Dimension ANSI B16.10

Flanged Ends ANSI 16.5

B.W. Ends ANSI B16.25

Drilling to ANSI, BS/AS 2129 Table D to H or PN10 to 100



— A1 —
Buttweld ends

OVERALL DIMENSIONS (MM & INCHES) & WEIGHT (KG)

VALVE SIZE (NPS)		inch	2	2-1/2	3	4	5	6	8	10	12
		mm	50	65	80	100	125	150	200	250	300
CLASS 150 (Table D to F) (PN10~21)	A-A1 (RF-BW)	inch	8	8-1/2	9-1/2	11-1/2	14	16	19-1/2	24-1/2	27-1/2
		mm	203	216	241	292	356	406	495	622	698.5
	B	inch	6-7/8	7	7-1/2	8-5/8	9-1/4	12-3/4	15-1/8	17-5/8	21-1/4
		mm	175	178	191	219	235	324	384	448	540
	Weight (kg)	RF	20	24	35	55	84	96	160	245	345
		BW	14	17	26	37	52	80	133	213	294
CLASS 300 (Table F to H) (PN25~50)	A-A1 (RF-BW)	inch	10-1/2	11-1/2	12-1/2	14	15-3/4	17-1/2	21	24-1/2	28
		mm	267	292	318	356	400	444	533	622	711
	B	inch	7-3/4	8	8-3/4	10-7/8	11-5/8	13-1/4	16-1/4	18-1/4	22-1/8
		mm	197	203	222	276	295	337	413	464	562
	Weight (kg)	RF	35	37	60	82	110	155	268	380	495
		BW	32	35	50	65	70	128	230	270	460
CLASS 600 (PN50~100)	A-A1 (RF-BW)	inch	11-1/2	13	14	17	20	22	26	31	33
		mm	292	330	356	432	508	559	660	787	838
	B	inch	8-1/4	8-5/8	10-1/2	11-3/4	13-1/4	15	18-3/4	21-5/8	22-5/8
		mm	210	219	267	299	337	381	476	549	670
	Weight (kg)	RF	40	55	72	120	175	270	420	620	810
		BW	31	45	60	85	125	225	365	500	715

GLOBE VALVE BELLOW SEALED BOLTED BONNET

OVERVIEW

- ASME B16.34 Design
- 15NB - 50NB (1/2 - 2") Bolted Bonnet
- Flange Ends, SW, NPT, BSP or Buttweld ends available 150 to 2500 Class
- Design - API 602, BS 5352, MSS SP11, ANSI/ASME B16.34
- End Connections
 - Socket Weld - ANSI/ASME B16.11
 - Thread - ANSI/ASME B1.20.1
 - Butt Weld - ANSI/ASME B16.25
 - Flange - ANSI/ASME B16.5
- Test and Inspection - API 598 / BS 5146

MATERIALS

No.	Part Name
1	Body
2	Disc
3	Split Ring
4	Disc Nut
5	Gasket
6	Bellows Holder Lower
7	Bonnet Bolt
8	Bellows
9	Stem*
10	Bonnet
11	Bonnet Upper
12	Guide Pin
13	Gland Packing**
14	Yoke
15	Gland
16	Gland Flange
17	Gland Nut
18	Gland Bolt
19	Thrust Washer
20	Yoke Sleeve
21	Handwheel
22	Handwheel Washer
23	Name Plate
24	Handwheel Nut

* Stem Smoothness $\leq Ra\ 0.80\ \mu m$
 ** Stuffing Box Smoothness $\leq Ra\ 3.2\ \mu m$

DESIGN FEATURES

- Inconel or 321SS Bellows
 - For longer life
 - Maximum corrosion resistance
- Flanged, screwed or welded end connections
- Welded or bolted bonnet design
- Zero stem leakage
 - Eliminates media loss
 - Satisfies environmental regulations
- Zero maintenance
 - Lower operating costs/no downtime
- Three stem seals for safety
 - Metallic bellows
 - Graphite packing
 - Backseat in open position
- Reduce monitoring costs
- Hardfaced seating surface
 - Stellite 6 for long life
- Valve designed, manufactured and tested
 - To ANSI B16.34/API 602 & 598
- Additional alloy and trims available
- For applications where leakage into or out of the valve is unacceptable
 - Heat transfer oil
 - Toxic fluids
 - Steam
 - Regulated media

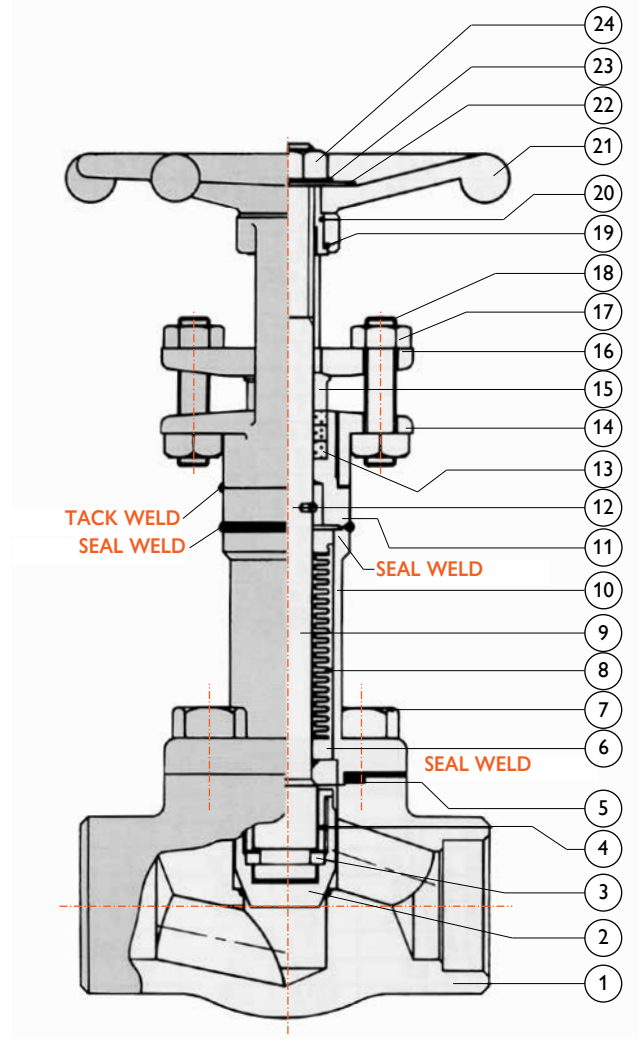

GATE VALVE BELLOW SEALED BOLTED BONNET

OVERVIEW

- ASME B16.34 Design
- 15NB - 50NB (1/2 - 2") Bolted Bonnet
- Flange Ends, SW, NPT, BSP or Buttweld ends available 150 to 2500 Class
- Design - API 602, BS 5352, MSS SP11, ANSI/ASME B16.34
- End Connections
 - Socket Weld - ANSI/ASME B16.11
 - Thread - ANSI/ASME B1.20.1
 - Butt Weld - ANSI/ASME B16.25
 - Flange - ANSI/ASME B16.5
- Test and Inspection - API 598 / BS 5146

MATERIALS

No.	Part Name
1	Body
2	Disc
3	Split Ring
5	Gasket
6	Bellows Holder Lower
7	Bonnet Bolt
8	Bellows
9	Stem*
10	Bonnet
11	Bonnet Upper
13	Gland Packing**
14	Yoke
15	Gland
16	Gland Flange
17	Gland Nut
18	Gland Bolt
19	Thrust Washer
20	Yoke Sleeve
21	Handwheel
22	Handwheel Washer
23	Name Plate
24	Handwheel Nut

* Stem Smoothness $\leq Ra\ 0.80\ \mu m$
 ** Stuffing Box Smoothness $\leq Ra\ 3.2\ \mu m$

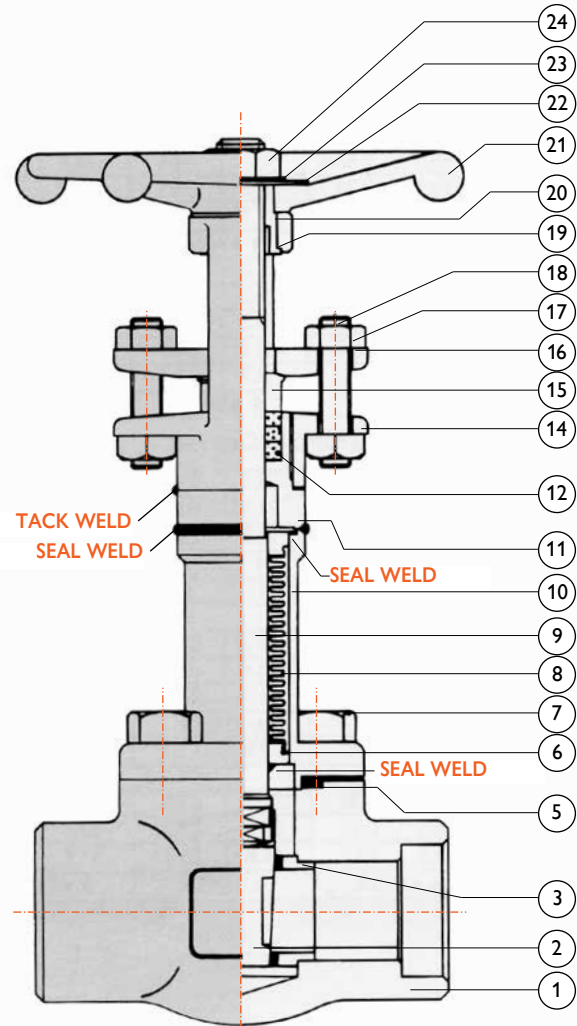

DESIGN FEATURES

- Inconel or 321SS Bellows
 - For longer life
 - Maximum corrosion resistance
- Flanged, screwed or welded end connections
- Welded or bolted bonnet design
- Zero stem leakage
 - Eliminates media loss
 - Satisfies environmental regulations
- Zero maintenance
 - Lower operating costs/no downtime
- Three stem seals for safety
 - Metallic bellows
 - Graphite packing
 - Backseat in open position
- Reduce monitoring costs
- Hardfaced seating surface
 - Stellite 6 for long life
- Valve designed, manufactured and tested
 - To ANSI B16.34/API 602 & 598
- Additional alloy and trims available
- For applications where leakage into or out of the valve is unacceptable
 - Heat transfer oil
 - Toxic fluids
 - Steam
 - Regulated media



AUSTRALIAN PIPELINE VALVE®

COMPLETE PRODUCT LINE

“Australian Pipeline Valve produces isolation, control and flow reversal protection products for severe and critical service media in utility, steam, pipelines, oil & gas and process industries. APV valves and pipeline products form the most competitive portfolio in the market.”



AUSTRALIAN PIPELINE VALVE BRAND RANGE - CATALOGUES

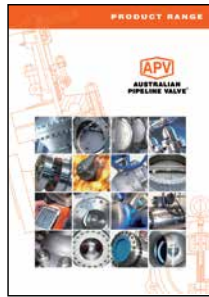

Product Brochure



Ball Valves Floating & Trunnion Mounted

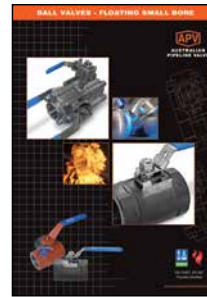

Ball Valves Floating Small Bore

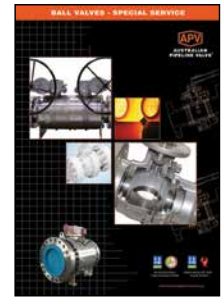

Ball Valves Special Service



Gate, Globe & Check Valves - Cast Steel



Gate, Globe & Check Valves - Forged Steel

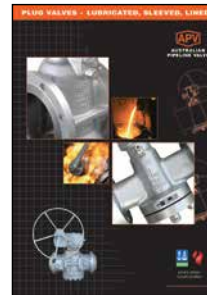

Plug Valves Lubricated, Sleeved & Lined

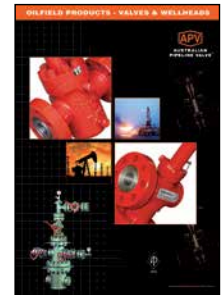

Oilfield Products - Valves & Wellheads

APV FAMILY OF BRANDS RANGE - CATALOGUES



Diamond Gear Gearboxes



Flowturn Ball Valves Multiway & Deadman



Flowturn Gate, Globe & Check Valves



Flowturn Instrument Valves



Flowturn Strainers & Sight Glasses



Steamco Steam Valves



Supercheck Wafer Check Valves



Superseal Butterfly Valves

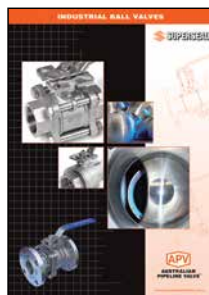

Superseal Industrial Ball Valves



Torqturn Actuators

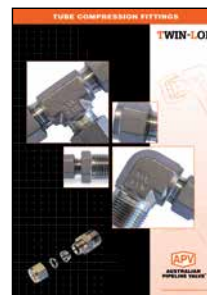

TwinLok Tube Fittings

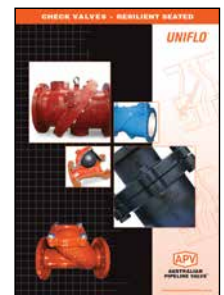

Uniflo Check Valves

Contact us for your local stockist/distributor



AUSTRALIAN PIPELINE VALVE®



www.australianpipelinevalve.com.au

LOCAL DISTRIBUTOR



QUALITY ASSURANCE AND CERTIFICATION

We are continually improving all facets of quality assurance. Full metallurgical and test certificates are always supplied for all pressure retaining parts, we also provide it on all major trim components.

We have endeavoured to provide a broad outline of our range and capabilities. Because we are continually developing new products for our customers this catalogue will, to some extent be incomplete. This catalogue is a general overview only, individual drawings and data sheets can be furnished on request.

If you have any requirement in the field of valves, please contact us for a prompt response. Continuous development of Australian Pipeline Valve products may necessitate changes in the design or manufacturing processes. Australian Pipeline Valve reserves the right to effect any such changes without prior notice.

